

In-line pH Electrode Fitting with ATC for S222C/CD (Model FC75TC) Product Instructions

Description of Parts

FC75TC consists of: 3/4" mounting gland (FC75P) used with Model S222C/CD Electrode, modified SCH80 PVC tee, cap and cable with temperature sensor in 1/4" nipple.

Mechanical Installation

Using Teflon tape or other pipe thread sealant on the connecting pipe threads and taking care to not overtighten plastic threads (particularly when screwing male metal pipe into female plastic fittings) proceed as follows:

- 1) Tee Installation: Install modified tee in-line making sure to position tee at least 10 degrees above the horizontal position. Refer to FIG. 1.
- 2) ATC Installation: Install the cable assembly's 1/4" nipple into the 1/4" NPT hole on the underside of the tee. Refer to FIG. 2.

Gland Installation

Using Teflon tape or other pipe thread sealant install the gland's 3/4" NPT thread into the top of the tee.

Do not overtighten. Refer to FIG. 3.

Electrode Installation

To install the S222C/CD electrode, loosen nut on top of gland by rotating counterclockwise. Slip electrode through hole in nut until desired insertion depth is reached. Once installed at the correct depth, tighten nut by turning clockwise (hand tighten only) Refer to FIG. 4

Cable Considerations

The gray plastic cap with the recessed BNC connector is fitted onto the electrode's connector. The exposed cable should be secured with supports to prevent cable sway.

The cable assembly mounts onto the electrode by a 1/4 turn which locks together the BNC connector on top of the S222C/CD electrode into the recessed BNC inside the cable's gray cap. It is important that the cable assembly be locked into position.

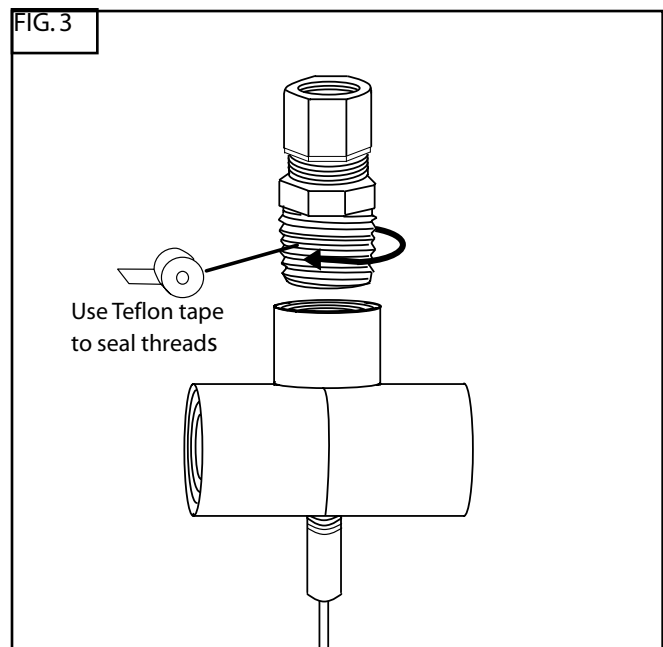
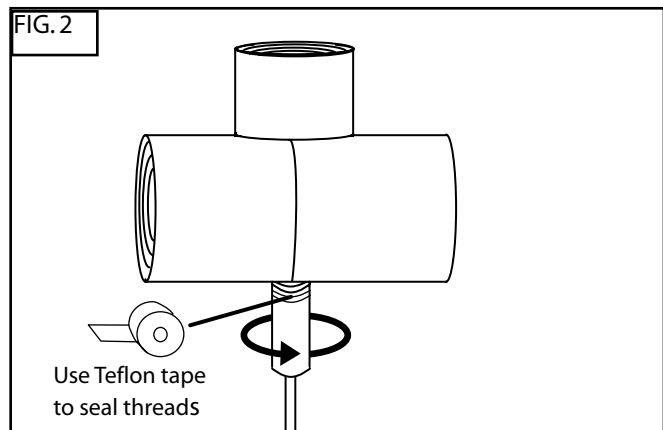
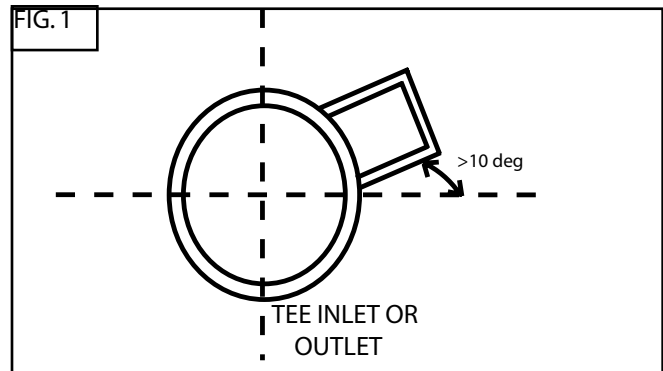

In-line pH Electrode Fitting with ATC for S222C/CD (Model FC75TC) Product Instructions

Follow the stepwise procedure below to install the cable onto the electrode (see FIG. 5):

- 1) While placing the cap over the electrode, rotate clockwise until it slips into the notches of the mating connector on the electrode.
- 2) Now, without further rotation, push the cap down onto the electrode as far as it will go.
- 3) Finally, rotate the cap again clockwise until it "clicks" into position or stops turning.

Reverse the above steps to remove the cable's cap from the electrode.

Electrical Installation

The pH preamplifier/transmitter/meter electrical connections are as follows:

pH - _____

Reference - _____

Temperature Compensator* - _____

Solution Ground** - _____

NOTES:

* Unless noted above, either temperature compensator lead (red or black wires) may be connected to either temperature compensator terminal strip connection.

** The green wire is for solution ground. Not all units have or require a solution ground. The pH meter/transmitter instructions should provide information about the use of this connection. If no reference is made to a solution (not earth) ground connection then it probably is not needed.

