

4-20mA DISSOLVED OXYGEN SENSOR CARE AND USE INSTRUCTIONS

How Dissolved Oxygen Sensors Work

Since your DO sensor includes an integral 4-20mA transmitter circuit, a 12-36V DC power supply is required to power your sensor so that it generates its signal. The Sensorex DO Probe will provide a milliamp signal proportional to the concentration of oxygen in the water. See SPECIFICATIONS on page 4, for preset factory output. Please note that range can be adjusted via your PLC or controller, but not at the probe. DO probes do not measure oxygen directly. They measure the partial pressure of oxygen in the water, which is directly proportional to the percent saturation of oxygen in the water. The concentration (mg/L or ppm) can be calculated based upon the oxygen solubility, temperature, salinity, and total atmospheric pressure.

Your Dissolved Oxygen Probe consists of a cathode, anode, and an electrolyte separated from your process fluid by an oxygen permeable membrane. The oxygen passing through the membrane reacts with the cathode, giving up electrons, which produces an electrical current.

Electrical Connections

First connect the sensor to the power supply (12-36 VDC) as follows:

Red wire of Sensor to Power Supply +
Black wire of Sensor to Power Supply -

Next, connect power supply to power outlet if using wall transformer. (See FIG. 1)

Multiple DO sensor with 4-20mA probe connection
Please note that the DO6241, DO6242, DO7241, DO7242's 4-20mA circuit is non-isolated. Therefore multiple probe inputs sharing a common power supply and connecting to the same load device (PLC, computer or controller) must be connected to 4-20mA loop isolators as shown in FIG. 2

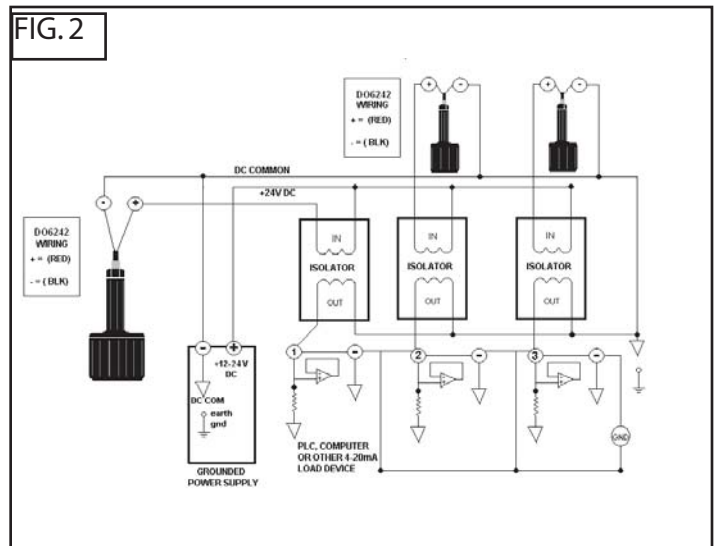
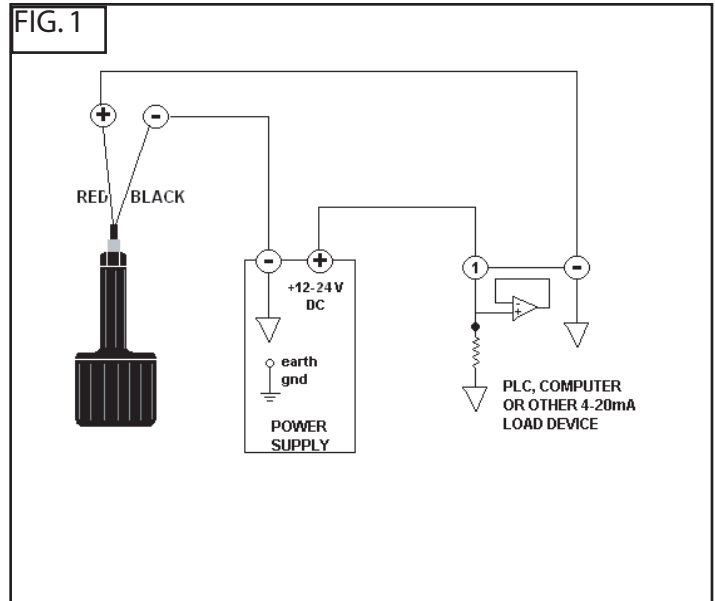

PRODUCT INSTRUCTION SHEET

Getting Your DO Sensor Ready to Use

Remove clear wire and label from vent hole on top of DO sensor as shown in FIG 3. Discard these parts after removing.

Calibration

The simplest method to calibrate your DO sensor is in air, since air is saturated with oxygen. You may also bubble oxygen or air into a bucket or beaker. The sensor is pre-calibrated at the factory (see Specifications Section for calibration range). If you prefer a 2-point calibration, a saturated solution of sodium sulfite (Na_2SO_3) is suggested. 17g Sodium sulfite in 125mL DI water is more than enough. Sodium sulfite will not reach a true zero output but it should reach less than 4.75mA (see Specifications Section for range).

Membrane Types

Sensorex offers two types of membrane materials for DO sensors, either PTFE or HDPE. Teflon offers excellent durability and moderate speed of response. HDPE offers fast response but less mechanical strength. The PTFE membrane also has less membrane permeability error with temperature as compared to HDPE. Spare membranes are available in 5 or 25 counts or in DOKIT-Teflon or DOKIT-HDPE.

Mounting Your DO Sensor

Submersion mounting of the sensor is recommended. To prevent air bubbles from becoming trapped on the membrane and producing falsely high DO readings, it is recommended that the sensor be mounted with the membrane pointing slightly upward (not horizontal) as shown in FIG. 4.

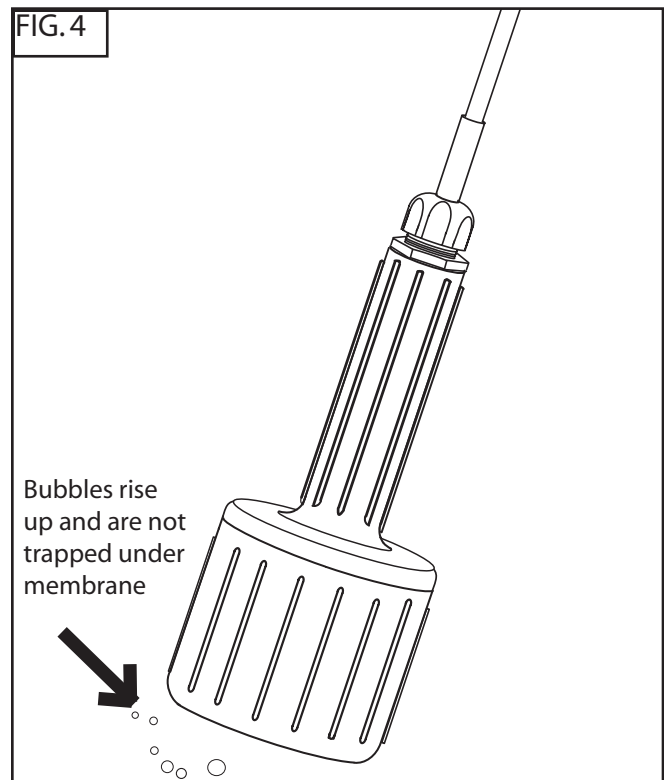
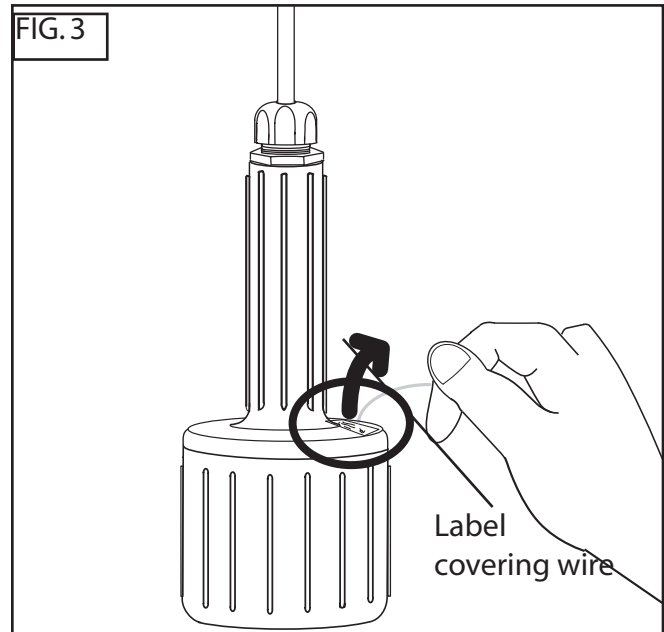

Parts covered by this product instruction sheet include:
DO6241, DO6242, DO7241, DO7242

Parts covered by this product instruction sheet include:
DO6242T, DO6242H, DO7242T, DO7242H

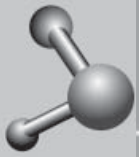

Sensor Re-Conditioning

1. Unscrew the lower body from the upper body (FIG. 5).
5) *NOTE: Industrial Dissolved Oxygen Sensors from Sensorex contain precision machined and molded parts. The top and bottom caps have been custom fitted at the factory. They must be "matched" with each other to ensure proper tensioning of the membrane. The bottom caps are NOT interchangeable with other top caps.*
2. Safely dispose of the electrolyte that is a special reagent grade Sodium Chloride solution (salt water) as shown in FIG. 6.
3. Using the Membrane Tool, unscrew the Membrane Lock in the lower body as shown in FIG. 7.
4. Remove and dispose of the membrane and its O-Ring as shown in FIG. 8.
5. Using a toothbrush, dish washing powder, and clean water, clean the cathode, anode, and plastic between them. Rinse all components thoroughly. Household Ammonia may be used to clean the silver anode overnight. If Ammonium Hydroxide is used, expose it for no more than 3 minutes (it is very strong). See FIG. 9.
6. Install a new O-Ring into the lower body membrane cavity, then a new membrane into the lower body. Using the Membrane Tool, screw the Membrane Lock on top of the membrane as shown in FIG. 10.
7. Inspect the membrane for wrinkles—replace if it is wrinkled.
8. Pour some water into the lower body and look for leakage around the membrane—replace it if there is leakage. If no leakage, dispose of the water.
9. Fill the lower body to its rim with fresh Electrolyte as shown in FIG. 11.
10. Inspect the large O-Ring between the upper and lower body. Replace it if it appears deteriorated. See FIG. 12.
11. Screw the lower body onto the upper body. Excess Electrolyte will squirt out of a small pressure balance hole atop the upper body. If no electrolyte squirts out, clear the hole of its blockage before installing the lower body.

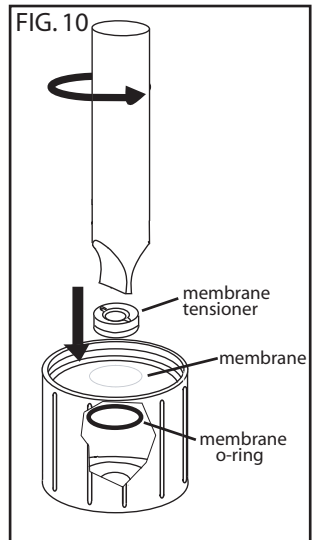
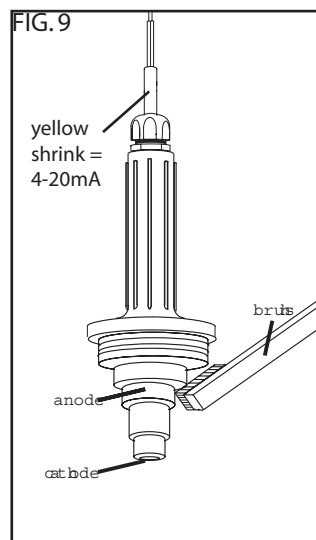
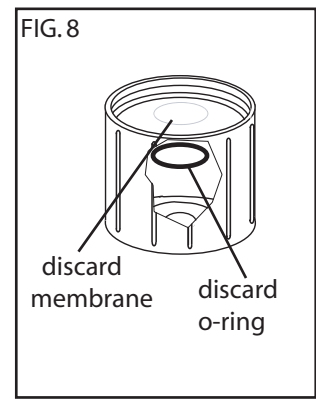
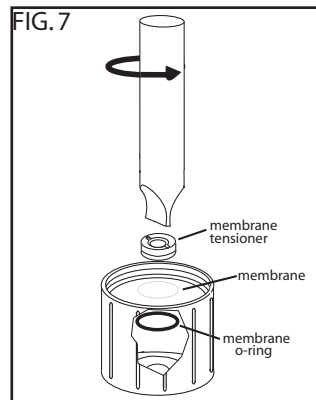
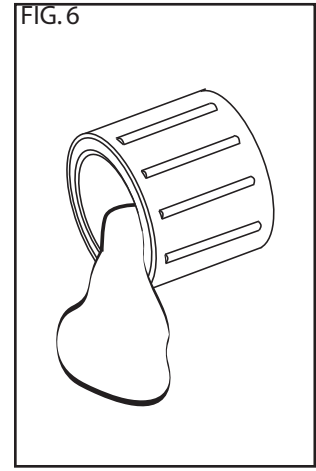
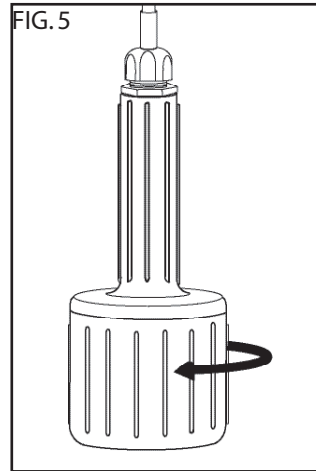

Parts covered by this product instruction sheet include:
DO6242T, DO6242H, DO7242T, DO7242H

PRODUCT SPECIFICATION SHEET

Sensor Storage

If long-term storage of probes is required, empty electrolyte out of probe leaving only a little solution on the membrane to keep it wet. Leaving a full volume of electrolyte in DO probe long-term without use will deplete the probes' anode. See section "RE-CONDITIONING YOUR DISSOLVED OXYGEN PROBE" for steps on how to open and close probe housing.

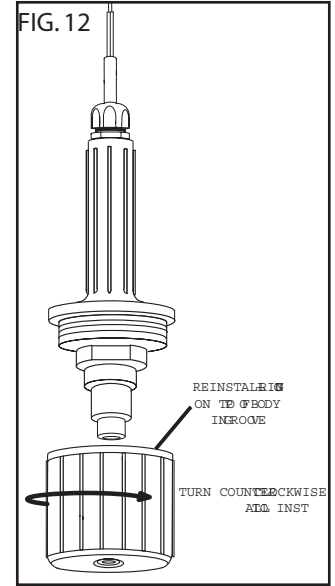
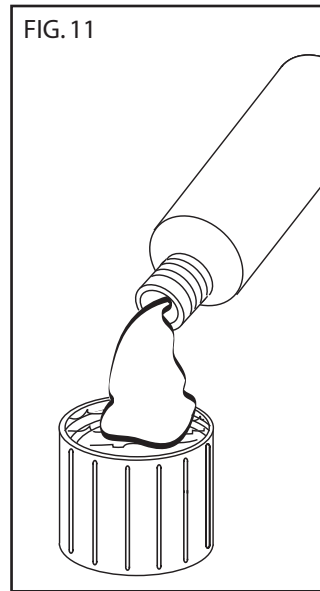

SPECIFICATIONS

Output at 100% saturation (DO6241, DO7241)	
PTFE membrane	15-20 mA
HDPE membrane	15-20 mA
Output at 100% saturation (DO6242, DO7242)	
PTFE membrane	7-10 mA
HDPE membrane	7-10 mA
Output at 0% saturation	
PTFE membrane	4.75 +/- 0.25mA
HDPE membrane	4.75 +/- 0.25mA
Temperature Range	
Max	50 deg C
Min	0 deg C
Accuracy	+/- 2% when measuring temp equal cal temp.
Response Time	
PTFE membrane	6 minutes to reach 90% of final reading
HDPE membrane	5 minutes to reach 95% of final reading
Water Flow Rate	Min 2 inch/second across membrane.
Wetted Materials	
Body	Delrin
Membrane	Teflon or HDPE
Wiring	
DO6242, DO7242	mA output/power supply connection: +Red, -Black
Power Supply Requirement	12-24V DC, 50mA

Teflon and Delrin are registered trademarks of E.I. DuPont.

SENSOREX[®]

11751 Markon Dr.
Garden Grove, CA 92841 USA

Tel: 714-895-4344
Fax: 714-894-4839
E-mail: info@sensorex.com
www.sensorex.com

Parts covered by this product instruction sheet include:
DO6241, DO6242, DO7241, DO7242