

Dissolved Oxygen Sensor Care and Use Instructions

Product Instructions

Introduction

Your Sensorex Dissolved Oxygen (DO) sensor is a galvanic electrochemical device; i.e. it does not require power from your meter or controller to generate its signal. The DO sensor will provide a millivolt signal proportional to the concentration of oxygen in the water (model DO6400, DO6400TC) or 4-20mA current output (models DO6441 and DO6442).

Your Dissolved Oxygen sensor consists of an cathode, anode, and an electrolyte separated from your process fluid by an oxygen permeable membrane. The oxygen passing through the membrane reacts at the cathode, giving up electrons, which produces an electrical current.

Electical Connections

DO6400 and DO6400TC models:

Red wire of Sensor to DO input + (cathode)
 Black wire of Sensor to DO input - (anode)
 White and Green wires of Sensor to Temperature input (10k NTC)
 (see wiring FIG 2.)

DO6441 and DO6442 models:

Red wire of Sensor to DO input + (cathode)
 Black wire of Sensor to DO input - (anode)
 (see wiring FIG 3.)

Getting Your DO Sensor Ready to Use

Your DO sensor is shipped to you dry and is not ready for use. See steps #1, #7, #8, #9 and #10 of the "Sensor Reconditioning" section of this sheet for instructions on sensor preparation. The installed membrane shipped with the probe is usable if it passes the leak test in step #8. Maintenance items included with your sensor include: 1 each membrane lock tool, 2 each PTFE or HDPE membranes, 2 each membrane o-rings and 250mL of electrolyte.

Calibration

First, ensure that the sensor is properly connected to the instrumentation circuitry. A visual display must be available to read the sensor output. For sensors that have been installed in service, gently wipe the membrane using a soft cloth to remove accumulated biological debris. The Probe may be calibrated in air, or in air-saturated water. Please calibrate out of direct sunlight, which may effect accurate calibration. The simplest method is to calibrate in air. To calibrate in air, turn the probe, so that the membrane is facing upward. Place a drop of clean water on the membrane. If calibrating in air saturated water, ensure that the water is saturated, by agitating the water sample. Place the probe just below the surface of the water level.

Parts covered by this product data sheet include:
 DO6400, DO6400TC, DO6441, DO6442

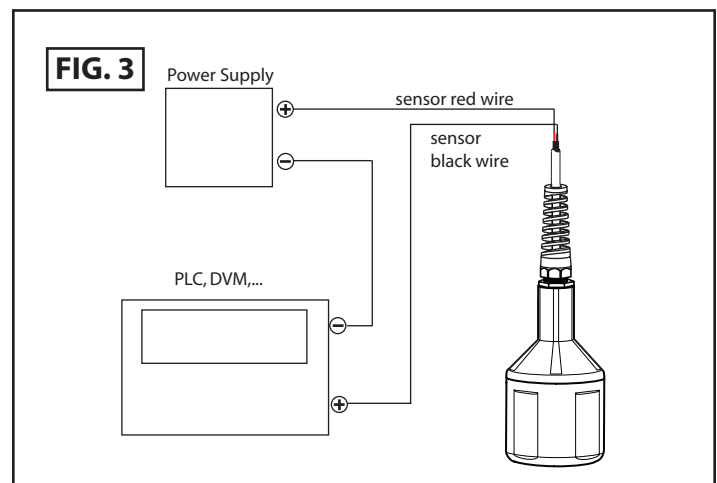
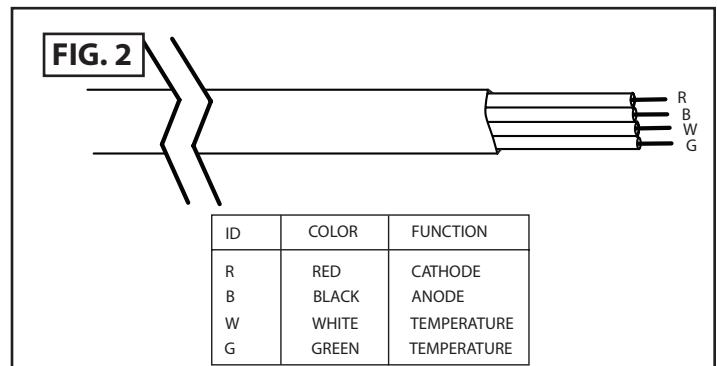
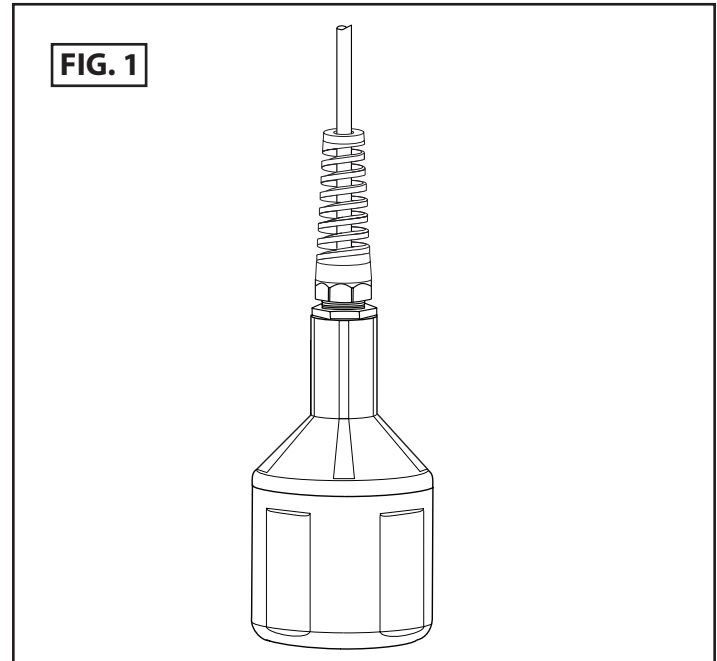

Allow the sensor to stabilize. A few minutes is adequate for a new probe or new membrane. If recalibrating a probe with an old membrane, several minutes may be required for stabilization.

Determine the atmospheric temperature and the barometric pressure and salinity. Using the charts on pages 5-7 of this instruction manual, determine the saturation value for this temperature, pressure and salinity. This 100% saturation value is equal to the millivolt output reading of the sensor (for series DO6400 and DO7400), or equal to the milliamp output of the sensor (for series DO6441, DO6442, DO7441, DO7442).

When the output is stable, indicating that temperature equalizing has taken place, measure the level of saturation. For example, using the DO6400/T electrode, a reading of 36.0 mV could be a typical saturated output reading. For the DO6442/T probe, a saturated reading in air could provide a calibration reading of 12.0 mA.

Most customers will find that this single point reading is satisfactory. The assumption is that the millivolt probes series DO6400 and DO7400 will read 0.0 mV when there is 0.00 ppm O₂. For series DO6441, DO6442, DO7441, DO7442, the assumption is the milliamp output of the sensor will be 4.25 mA. The output of all of these sensors are linear. For customers routinely measuring 3 or more ppm, the assumptions will provide excellent results. Using these 2 points, a line may be drawn between these 2 points. All subsequent readings will fall on this line, or for higher values, beyond the extended line to higher levels of O₂ saturation at higher pressures.

Should you expect readings below 2 ppm, you should perform a 2 point calibration. Prepare a solution of saturated sodium sulfite (Na₂SO₃) in water. 17g Sodium sulfite in 125mL DI water is more than enough. Sodium sulfite may not reach a true zero output on your display but it should read less than 2 mV for series DO6400 and DO7400, and less than 5mA for series DO6441, DO6442, DO7441, DO7442 after 5 minutes.

Calibration should be performed periodically to ensure the best accuracy. The application will determine the interval of calibration. The user is responsible to understand how often calibration will be performed for that application.

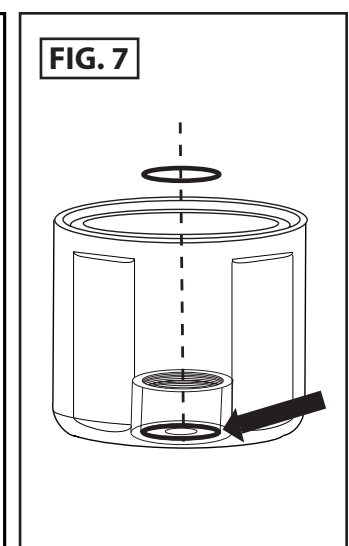
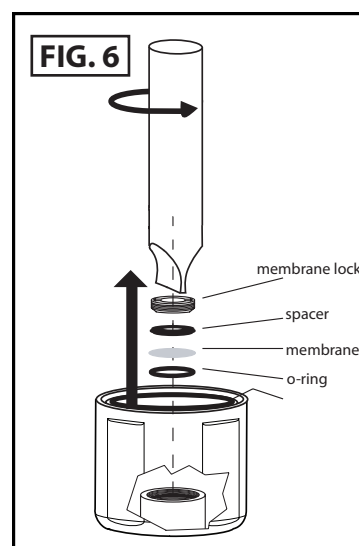
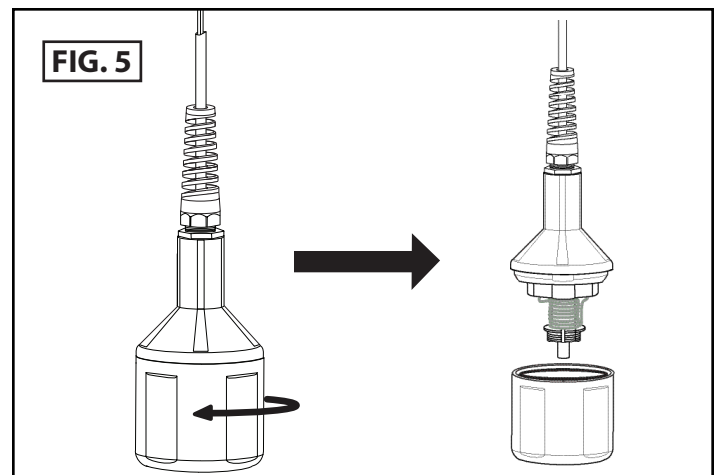
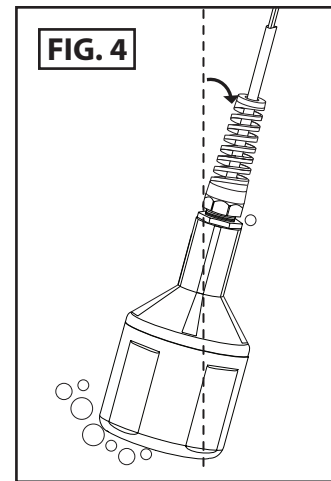

Mounting Your DO Sensor

Submersion mounting of the sensor is recommended. To prevent air bubbles from becoming trapped on the membrane and producing falsely high DO readings, it is recommended that the sensor be mounted at a slight angle (SEE FIG. 4).

Sensor Re-Conditioning

1. Unscrew the lower body from the upper body (FIG. 5).
2. Safely dispose of the electrolyte (Sodium Chloride solution (salt water). Make sure o-ring does not fall out of cap.
3. Using the Membrane Tool, unscrew the Membrane Lock in the lower body as shown in FIG. 6
4. Remove and dispose of the membrane and its o-ring as show in FIG 6.
5. To clean, take the top part of the sensor and immerse in distilled white vinegar (3% acetic acid) for about 30 minutes. If you don't have vinegar, you can use a SOFT toothbrush, dish washing powder, and clean water, clean the cathode, anode, and plastic between them. Rinse all components thoroughly with clean water after cleaning (SEE FIG. 8).
6. First, install a new o-ring into the lower body membrane cavity (the o-ring must go all the way to the bottom as shown in FIG 7), then a new membrane (*remove paper backing from membrane before installing*), then the spacer. Using the Membrane tool, install the Membrane Lock on top of the spacer as shown in FIG. 9. Make sure cap is upright (not sideways) when screwing in lock.
7. Inspect the membrane for wrinkles--replace if it is wrinkled.
8. Pour some clean water into the lower body and look for leakage around the membrane (SEE FIG. 10)--replace if there is leakage. If there is no leakage, dispose of the water.
9. Fill the bottom cap to the top with fresh electrolyte.
10. Keep the sensor upright so that the cable is pointed upwards(not sideways). Screw the bottom cap onto the upper body until hand tight. Excess electrolyte will leak out at the joint between the sensor's cap and upper body.

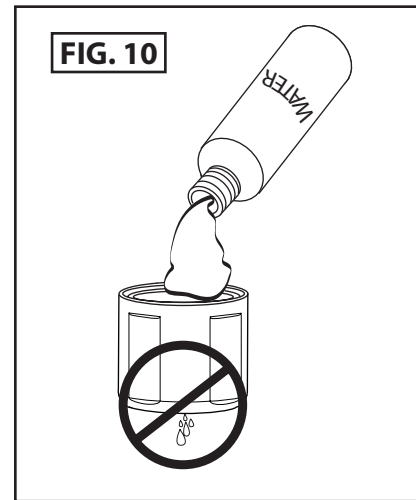
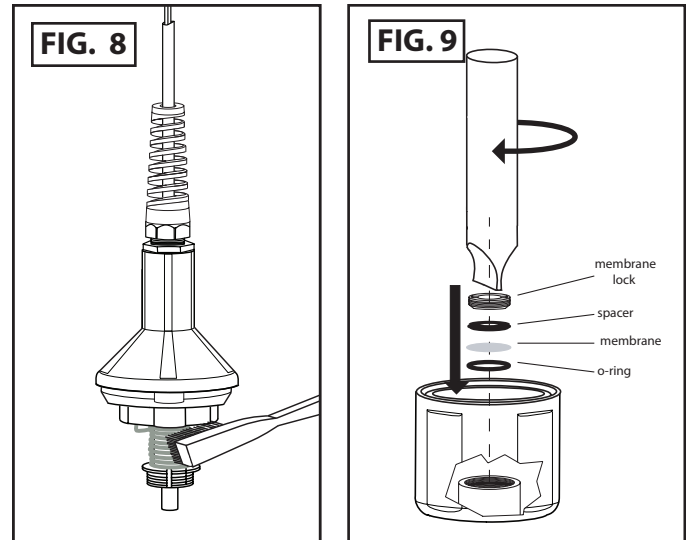

Sensor Repair

Do not attempt to repair any part of the sensor. If the sensor's cable is damaged, consult the factory for details.

Sensor Storage

If long-term storage of probes is required, empty electrolyte out of probe, rinse with clean water and remove the membrane. *Store dry and empty.*

SPECIFICATIONS

Sensor Materials	
Top and Bottom Cap:	Noryl [®]
Sensor Body:	Delrin [®]
Anode:	Zinc wire
Cathode:	Silver
Output at 100% Saturation (mV models)	
PTFE Membrane:	33+/-9 mV
HDPE Membrane:	45+/-9 mV
Output at 100% Saturation (mA models)	
D06441:	18-22mA
D06442:	11-13mA
Output at 0% Saturation (mV models)	
PTFE & HDPE Membrane:	<1mV
Output at 0% Saturation (mA models) <4.5mA	
Temperature Range	
Max:	50 deg C
Min:	0 deg C
Response Time	
PTFE Membrane:	5 minutes from 100% to 0% Oxygen (<1mV or 4.5mA)
Water Flow Rate:	Min 2 inch/second across membrane.
Wetted Materials	
Body:	Noryl [®]
Membrane:	PTFE or HDPE
Cable:	4-conductor, 24AWG, Copper/PVC, polyurethane outer jacket.
Wiring	
D06400, D06441*, D06442*	Red = +, Black = -
D06400/TC	Red = +, Black = - White = Temp, Green = Temp
Note: * 4-20mA output versions PTFE is a registered trademark of E.I. DuPont de Nemours Co. Delrin is a registered trademark of E.I. DuPont de Nemours Co. Noryl is a registered trademark of General Electric Company	

Outline and Dimensions

D06400TC

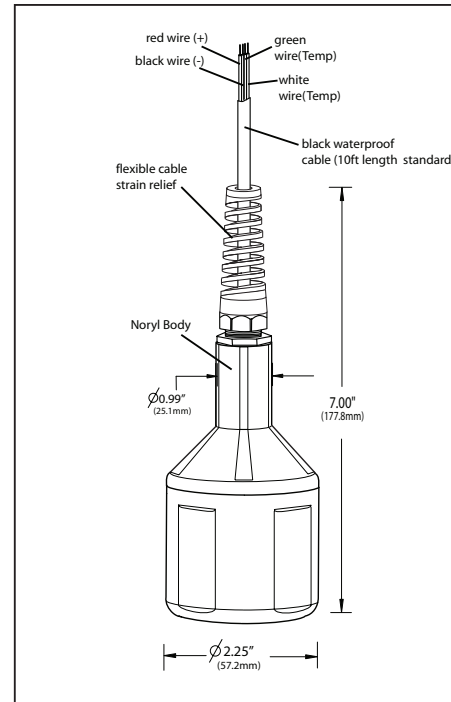

D06400 and D06441, 6442

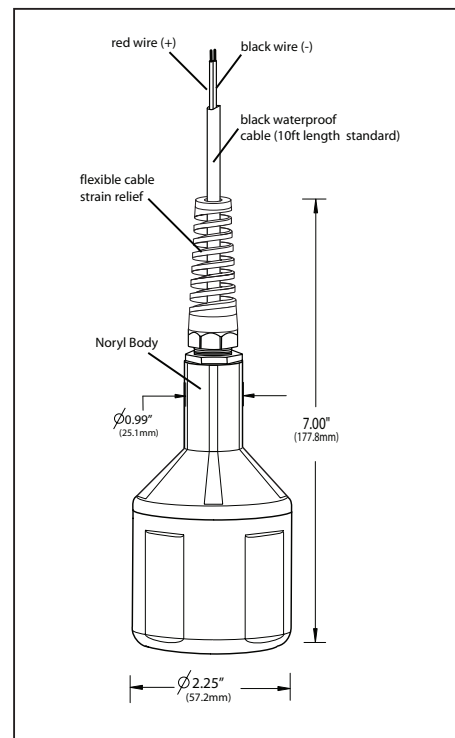

TEMPERATURE		SALINITY- in parts per thousand (ppt)								
deg C	deg F	0	5	10	15	20	25	30	35	40
0	32	14.6	14.11	13.64	13.18	12.74	12.31	11.9	11.5	11.11
1	33.8	14.2	13.73	13.27	12.83	12.4	11.98	11.58	11.2	10.83
2	35.6	13.81	13.36	12.91	12.49	12.07	11.67	11.29	10.91	10.55
3	37.4	13.45	13	12.58	12.16	11.76	11.38	11	10.64	10.29
4	39.2	13.09	12.67	12.25	11.85	11.47	11.09	10.73	10.38	10.04
5	41	12.76	12.34	11.94	11.56	11.18	10.82	10.47	10.13	9.8
6	42.8	12.44	12.04	11.65	11.27	10.91	10.56	10.22	9.89	9.57
7	44.6	12.13	11.74	11.37	11	10.65	10.31	9.98	9.66	9.35
8	46.4	11.83	11.46	11.09	10.74	10.4	10.07	9.75	9.44	9.14
9	48.2	11.55	11.19	10.83	10.49	10.16	9.84	9.53	9.23	8.94
10	50	11.28	10.92	10.58	10.25	9.93	9.62	9.32	9.03	8.75
11	51.8	11.02	10.67	10.34	10.02	9.71	9.41	9.12	8.83	8.56
12	53.6	10.77	10.43	10.11	9.8	9.5	9.21	8.92	8.55	8.3
13	55.4	10.53	10.2	9.89	9.59	9.3	9.01	8.74	8.47	8.21
14	57.2	10.29	9.98	9.68	9.38	9.1	8.82	8.55	8.3	8.04
15	59	10.07	9.77	9.47	9.19	8.91	8.64	8.38	8.13	7.88
16	60.8	9.86	9.56	9.28	9	8.73	8.47	8.21	7.97	7.73
17	62.6	9.65	9.36	9.09	8.82	8.55	8.3	8.05	7.81	7.58
18	64.4	9.45	9.17	8.9	8.64	8.39	8.14	7.9	7.66	7.44
19	66.2	9.26	8.99	8.73	8.47	8.22	7.98	7.75	7.52	7.3
20	68	9.08	8.81	8.56	8.31	8.07	7.83	7.6	7.38	7.17
21	69.8	8.9	8.64	8.39	8.15	7.91	7.69	7.46	7.25	7.04
22	71.6	8.73	8.48	8.23	8	7.77	7.54	7.33	7.12	6.91
23	73.4	8.56	8.32	8.08	7.85	7.63	7.41	7.2	6.99	6.79
24	75.2	8.4	8.16	7.93	7.71	7.49	7.28	7.07	6.87	6.68
25	77	8.24	8.01	7.79	7.57	7.36	7.15	6.95	6.75	6.56
26	78.8	8.09	7.87	7.65	7.44	7.23	7.03	6.83	6.64	6.46
27	80.6	7.95	7.73	7.51	7.31	7.1	6.91	6.72	6.53	6.35
28	82.4	7.81	7.59	7.38	7.18	6.98	6.79	6.61	6.42	6.25
29	84.2	7.67	7.46	7.26	7.06	6.87	6.68	6.5	6.32	6.15
30	86	7.54	7.33	7.14	6.94	6.75	6.57	6.39	6.22	6.05
31	87.8	7.41	7.21	7.02	6.83	6.65	6.47	6.29	6.12	5.96
32	89.6	7.29	7.09	6.9	6.72	6.54	6.36	6.19	6.03	5.87
33	91.4	7.17	6.98	6.79	6.61	6.44	6.26	6.1	5.94	5.78
34	93.2	7.05	6.86	6.68	6.51	6.33	6.17	6.01	5.85	5.69
35	95	6.93	6.75	6.58	6.4	6.24	6.07	5.92	5.76	5.61
36	96.8	6.82	6.65	6.47	6.31	6.14	5.98	5.83	5.68	5.53
37	98.6	6.72	6.54	6.37	6.21	6.05	5.89	5.74	5.59	5.45
38	100.4	6.61	6.44	6.28	6.12	5.96	5.81	5.66	5.51	5.37
39	102.2	6.51	6.34	6.18	6.03	5.87	5.72	5.58	5.44	5.3
40	104	6.41	6.25	6.09	5.94	5.79	5.64	5.5	5.36	5.22

TEMP (°C)	PRESSURE (TORR)									
	750	755	760	765	770	775	780	785	790	795
0	14.37	14.47	14.57	14.66	14.76	14.86	14.95	15.05	15.15	15.24
1	13.98	14.08	14.17	14.27	14.36	14.45	14.55	14.64	14.73	14.83
2	13.61	13.70	13.79	13.88	13.97	14.07	14.16	14.25	14.34	14.43
3	13.25	13.34	13.43	13.52	13.61	13.69	13.78	13.87	13.96	14.05
4	12.90	12.99	13.08	13.16	13.25	13.34	13.42	13.51	13.60	13.68
5	12.57	12.66	12.74	12.83	12.91	13.00	13.08	13.16	13.25	13.33
6	12.25	12.34	12.42	12.50	12.58	12.67	12.75	12.83	12.91	13.00
7	11.95	12.03	12.11	12.19	12.27	12.35	12.43	12.51	12.59	12.67
8	11.66	11.74	11.81	11.89	11.97	12.05	12.13	12.21	12.29	12.36
9	11.38	11.45	11.53	11.61	11.68	11.76	11.84	11.91	11.99	12.07
10	11.11	11.18	11.26	11.33	11.41	11.48	11.56	11.63	11.71	11.78
11	10.85	10.92	10.99	11.07	11.14	11.21	11.29	11.36	11.43	11.51
12	10.60	10.67	10.74	10.81	10.89	10.96	11.03	11.10	11.17	11.24
13	10.36	10.43	10.50	10.57	10.64	10.71	10.78	10.85	10.92	10.99
14	10.13	10.20	10.27	10.34	10.41	10.48	10.54	10.61	10.68	10.75
15	9.91	9.98	10.05	10.11	10.18	10.25	10.32	10.38	10.45	10.52
16	9.70	9.77	9.83	9.90	9.96	10.03	10.10	10.16	10.23	10.29
17	9.50	9.56	9.63	9.69	9.76	9.82	9.89	9.95	10.01	10.08
18	9.30	9.37	9.43	9.49	9.56	9.62	9.68	9.75	9.81	9.87
19	9.12	9.18	9.24	9.30	9.36	9.43	9.49	9.55	9.61	9.67
20	8.93	9.00	9.06	9.12	9.18	9.24	9.30	9.36	9.42	9.48
21	8.76	8.82	8.88	8.94	9.00	9.06	9.12	9.18	9.24	9.30
22	8.59	8.65	8.71	8.77	8.83	8.89	8.95	9.01	9.06	9.12
23	8.43	8.49	8.55	8.61	8.66	8.72	8.78	8.84	8.90	8.95
24	8.28	8.33	8.39	8.45	8.50	8.56	8.62	8.67	8.73	8.79
25	8.13	8.18	8.24	8.29	8.35	8.41	8.46	8.52	8.57	8.63
26	7.98	8.04	8.09	8.15	8.20	8.26	8.31	8.37	8.42	8.48
27	7.84	7.89	7.95	8.00	8.06	8.11	8.17	8.22	8.27	8.33
28	7.70	7.76	7.81	7.86	7.92	7.97	8.02	8.08	8.13	8.18
29	7.57	7.63	7.68	7.73	7.78	7.84	7.89	7.94	7.99	8.05
30	7.44	7.50	7.55	7.60	7.65	7.70	7.76	7.81	7.86	7.91
31	7.32	7.37	7.42	7.47	7.52	7.58	7.63	7.68	7.73	7.78
32	7.20	7.25	7.30	7.35	7.40	7.45	7.50	7.55	7.60	7.65
33	7.08	7.13	7.18	7.23	7.28	7.33	7.38	7.43	7.48	7.53
34	6.97	7.02	7.07	7.11	7.16	7.21	7.26	7.31	7.36	7.41
35	6.86	6.90	6.95	7.00	7.05	7.10	7.15	7.19	7.24	7.29
36	6.75	6.79	6.84	6.89	6.94	6.98	7.03	7.08	7.13	7.18
37	6.64	6.69	6.73	6.78	6.83	6.88	6.92	6.97	7.02	7.06
38	6.53	6.58	6.63	6.67	6.72	6.77	6.81	6.86	6.91	6.95
39	6.43	6.48	6.52	6.57	6.62	6.66	6.71	6.75	6.80	6.85
40	6.33	6.38	6.42	6.47	6.51	6.56	6.60	6.65	6.70	6.74
41	6.23	6.28	6.32	6.37	6.41	6.46	6.50	6.55	6.59	6.64
42	6.13	6.18	6.22	6.27	6.31	6.36	6.40	6.45	6.49	6.53
43	6.04	6.08	6.13	6.17	6.21	6.26	6.30	6.35	6.39	6.43
44	5.94	5.99	6.03	6.07	6.12	6.16	6.20	6.25	6.29	6.33
45	5.85	5.89	5.94	5.98	6.02	6.06	6.11	6.15	6.19	6.24
46	5.76	5.80	5.84	5.88	5.93	5.97	6.01	6.06	6.10	6.14
47	5.67	5.71	5.75	5.79	5.83	5.88	5.92	5.96	6.00	6.05
48	5.57	5.62	5.66	5.70	5.74	5.78	5.83	5.87	5.91	5.95
49	5.49	5.53	5.57	5.61	5.65	5.69	5.73	5.78	5.82	5.86
50	5.40	5.44	5.48	5.52	5.56	5.60	5.64	5.68	5.72	5.77

¹To convert pressure (inches of Hg) to pressure (mm of Hg (torr)), multiply by 25.4.

TEMP(c)	PRESSURE (Inches Hg.)										Concentration (mg/L) of Dissolved O ₂ at Saturation by Temperature and Barometric Pressure ¹
	29.5	29.7	29.9	30.1	30.3	30.5	30.7	30.9	31.1	31.3	
0	14.37	14.47	14.57	14.66	14.76	14.86	14.95	15.05	15.15	15.24	
1	13.98	14.08	14.17	14.27	14.36	14.45	14.55	14.64	14.73	14.83	
2	13.61	13.70	13.79	13.88	13.97	14.07	14.16	14.25	14.34	14.43	
3	13.25	13.34	13.43	13.52	13.61	13.69	13.78	13.87	13.96	14.05	
4	12.90	12.99	13.08	13.16	13.25	13.34	13.42	13.51	13.60	13.68	
5	12.57	12.66	12.74	12.83	12.91	13.00	13.08	13.16	13.25	13.33	
6	12.25	12.34	12.42	12.50	12.58	12.67	12.75	12.83	12.91	13.00	
7	11.95	12.03	12.11	12.19	12.27	12.35	12.43	12.51	12.59	12.67	
8	11.66	11.74	11.81	11.89	11.97	12.05	12.13	12.21	12.29	12.36	
9	11.38	11.45	11.53	11.61	11.68	11.76	11.84	11.91	11.99	12.07	
10	11.11	11.18	11.26	11.33	11.41	11.48	11.56	11.63	11.71	11.78	
11	10.85	10.92	10.99	11.07	11.14	11.21	11.29	11.36	11.43	11.51	
12	10.60	10.67	10.74	10.81	10.89	10.96	11.03	11.10	11.17	11.24	
13	10.36	10.43	10.50	10.57	10.64	10.71	10.78	10.85	10.92	10.99	
14	10.13	10.20	10.27	10.34	10.41	10.48	10.54	10.61	10.68	10.75	
15	9.91	9.98	10.05	10.11	10.18	10.25	10.32	10.38	10.45	10.52	
16	9.70	9.77	9.83	9.90	9.96	10.03	10.10	10.16	10.23	10.29	
17	9.50	9.56	9.63	9.69	9.76	9.82	9.89	9.95	10.01	10.08	
18	9.30	9.37	9.43	9.49	9.56	9.62	9.68	9.75	9.81	9.87	
19	9.12	9.18	9.24	9.30	9.36	9.43	9.49	9.55	9.61	9.67	
20	8.93	9.00	9.06	9.12	9.18	9.24	9.30	9.36	9.42	9.48	
21	8.76	8.82	8.88	8.94	9.00	9.06	9.12	9.18	9.24	9.30	
22	8.59	8.65	8.71	8.77	8.83	8.89	8.95	9.01	9.06	9.12	
23	8.43	8.49	8.55	8.61	8.66	8.72	8.78	8.84	8.90	8.95	
24	8.28	8.33	8.39	8.45	8.50	8.56	8.62	8.67	8.73	8.79	
25	8.13	8.18	8.24	8.29	8.35	8.41	8.46	8.52	8.57	8.63	
26	7.98	8.04	8.09	8.15	8.20	8.26	8.31	8.37	8.42	8.48	
27	7.84	7.89	7.95	8.00	8.06	8.11	8.17	8.22	8.27	8.33	
28	7.70	7.76	7.81	7.86	7.92	7.97	8.02	8.08	8.13	8.18	
29	7.57	7.63	7.68	7.73	7.78	7.84	7.89	7.94	7.99	8.05	
30	7.44	7.50	7.55	7.60	7.65	7.70	7.76	7.81	7.86	7.91	
31	7.32	7.37	7.42	7.47	7.52	7.58	7.63	7.68	7.73	7.78	
32	7.20	7.25	7.30	7.35	7.40	7.45	7.50	7.55	7.60	7.65	
33	7.08	7.13	7.18	7.23	7.28	7.33	7.38	7.43	7.48	7.53	
34	6.97	7.02	7.07	7.11	7.16	7.21	7.26	7.31	7.36	7.41	
35	6.86	6.90	6.95	7.00	7.05	7.10	7.15	7.19	7.24	7.29	
36	6.75	6.79	6.84	6.89	6.94	6.98	7.03	7.08	7.13	7.18	
37	6.64	6.69	6.73	6.78	6.83	6.88	6.92	6.97	7.02	7.06	
38	6.53	6.58	6.63	6.67	6.72	6.77	6.81	6.86	6.91	6.95	
39	6.43	6.48	6.52	6.57	6.62	6.66	6.71	6.75	6.80	6.85	
40	6.33	6.38	6.42	6.47	6.51	6.56	6.60	6.65	6.70	6.74	
41	6.23	6.28	6.32	6.37	6.41	6.46	6.50	6.55	6.59	6.64	
42	6.13	6.18	6.22	6.27	6.31	6.36	6.40	6.45	6.49	6.53	
43	6.04	6.08	6.13	6.17	6.21	6.26	6.30	6.35	6.39	6.43	
44	5.94	5.99	6.03	6.07	6.12	6.16	6.20	6.25	6.29	6.33	
45	5.85	5.89	5.94	5.98	6.02	6.06	6.11	6.15	6.19	6.24	
46	5.76	5.80	5.84	5.88	5.93	5.97	6.01	6.06	6.10	6.14	
47	5.67	5.71	5.75	5.79	5.83	5.88	5.92	5.96	6.00	6.05	
48	5.57	5.62	5.66	5.70	5.74	5.78	5.83	5.87	5.91	5.95	
49	5.49	5.53	5.57	5.61	5.65	5.69	5.73	5.78	5.82	5.86	
50	5.40	5.44	5.48	5.52	5.56	5.60	5.64	5.68	5.72	5.77	

¹To convert pressure (inches of Hg) to pressure (mm of Hg (torr)), multiply by 25.4.