

# Free Chlorine Amperometric 4-20mA Sensors

## SECTION 1.0 THEORY OF OPERATION

**1.0 FREE CHLORINE DEFINED.** Free Chlorine or "freely active chlorine" is defined as the sum of molecular chlorine (Cl<sub>2</sub>), hypochlorous acid (HOCl) and hypochlorite ions (OCl<sup>-</sup>). Molecular chlorine occurs at pH values <pH4. Hypochlorous acid and hypochlorite ions are in pH dependent equilibrium with one another as shown in FIG 1.

The graph shows % hypochlorous acid on the left of the curve. Hypochlorous acid is a much stronger disinfecting agent (oxidizer) as compared to hypochlorite ions.

**1.2 SENSOR OPERATING PRINCIPLE.** Both hypochlorous acid (HOCl) and hypochlorite ion (OCl<sup>-</sup>) diffuse through the membrane between the cathode and sample solution, even though the diffusion coefficients for each are different. At the applied potential, only hypochlorous acid is electrochemically reduced. HOCl is reduced to chloride ion at the gold cathode. At the same time, the silver anode is oxidized to form silver chloride (AgCl). When the concentration of HOCl at the cathode is dramatically decreased by electrochemical reduction, hypochlorite ion will be transformed into hypochlorous acid, to some extent, by proton transfer. The release of electrons at the cathode and acceptance at the anode creates a current flow, which under constant conditions, is proportional to the free chlorine concentration in the medium outside the sensor. The resulting low current output is then conditioned to 4-20mA current by the sensor's onboard electronic circuitry.

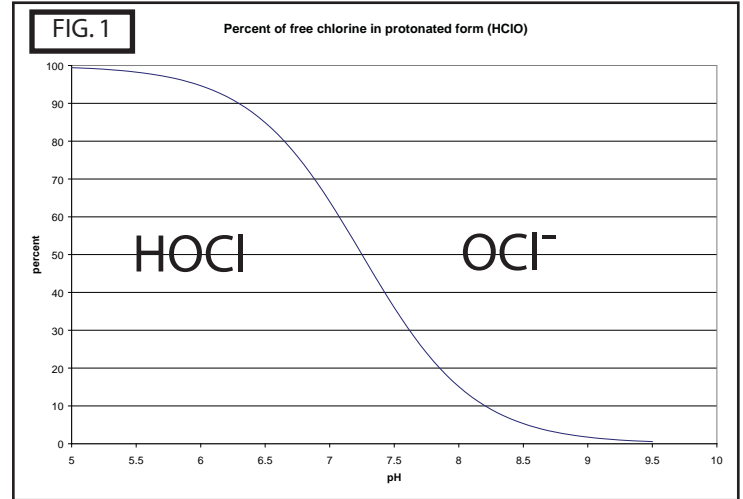

TABLE 1

pH Range	<6.5	6.5-7.5	7.5-8.3	8.3-9.0
pH Variation	N/A	± 0.35	± 0.20	± 0.05

## SECTION 2.0

### FACTORS INFLUENCING THE SENSOR

**2.1 pH.** Free Chlorine (FCL) exists as hypochlorous acid and hypochlorite anion (FIG 1). The acid-base dissociation of FCL has a pKa of approximately 7.5. The FCL sensor responds to hypochlorous acid and hypochlorite anion with different sensitivity. In combination, an increase in pH reduces the measured FCL and decrease in pH increases the measured FCL. The need for automatic pH compensation depends on the pH value and the variation range of pH (Table 1). If pH variation of your sample is more than that listed in the table, automatic pH compensation is required. pH compensation for the sensors current (mA) reading is:

$$(sensor\ output\ in\ mA - 4) / (-0.0502pH^3 + 0.867pH^2 - 5.051pH + 12.43) + 4$$

**2.2 Chemical Interferences.** The sensors should not be used in water containing surfactants, organic chlorine or stabilizers such as cyanuric acid.

**2.2 FLOW.** The membrane covered free chlorine sensors (FCL series) functions at any flow rate. To achieve reproducible measurements, these free chlorine sensors require a specified constant flow rate. To avoid complications (such as bubbles), it is best to operate the sensors at a flow rate of 0.2-0.6 gpm if using flow cell FC72 or FC70 (old version).

Parts covered by this product instruction sheet include: FCL202, FCL205, FCL210, FC72, FCLA-2015, FCLA-2016



### SECTION 3.0 SENSOR PREPARATION

**3.0 FREE CHLORINE SENSOR ASSEMBLY.** The Free Chlorine Sensor is shipped with the membrane cap pre-installed and covered with a cap with water inside to keep the membrane wet. Make sure to keep sensor cap, anode and cathode inside the sensor body, away oily or greasy materials. Contact with oil or grease will result in inaccurate measurements.

**NOTE:** IF SENSOR WILL BE STORED DRY OUT OF FLOW CELL, SHAKE BODY DOWNWARD INTO A SINK TO REMOVE THE FILL SOLUTION. TAKE THE MEMBRANE CAP AND IMMERSIVE IN A CUP OF TAP WATER UNTILL READY TO REUSE. SEE SECTION 9. REPLACE CAP AND ELECTROLYTE BEFORE INSTALLING INTO FLOW CELL (see SECTION 10 for cap and electrolyte change. See SECTION 5 for sensor installation into flow cell).

### SECTION 4.0 FLOW CELL INSTALLATION

**4.0 FLOW CELL.** To obtain accurate Free Chlorine reading, the Sensor must be installed into the Flow Cell to prevent air bubbles formation on the membrane, proper spacing between the sensor and the installation wall, and laminar flow across the membrane.

- 4.1. Using two 1/4" NPT Tube fittings, connect the FC72 Flow Cell into your system, noting the inlet (bottom) and outlet (side) orientation. (see FIGURE 2)
- 4.2. Install clamp with rubber backing as shown in FIG. 2A.
- 4.3 Drill 3/8" diameter hole on the panel.
- 4.4 Insert bolt as shown in FIG 2A
- 4.5 On back of panel attach lock washer and nut to secure clamp and flow cell to panel.

### SECTION 5.0 SENSOR INSTALLATION

- 5.0 SENSOR INSTALLATION INTO FLOW CELL.**
- a. First install threaded fitting onto sensor body (remove fitting if pre-installed in flow cell)
  - b. Install snap-ring into groove on sensor body
  - c. Next, slide o-ring onto body of sensor until it reaches bottom of threaded fitting.
  - d. Thread sensor assembly into top of flow cell as shown in FIGURE 2.
  - d. Turn on flow and verify the flow through the Flow Cell is at least 0.2gpm (45 liters/hour) and no more than 0.6gpm (135 liters/hour).

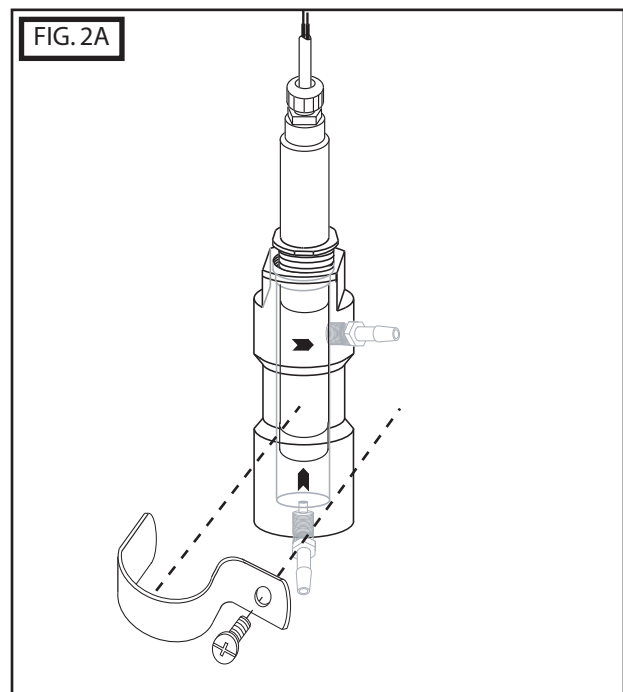
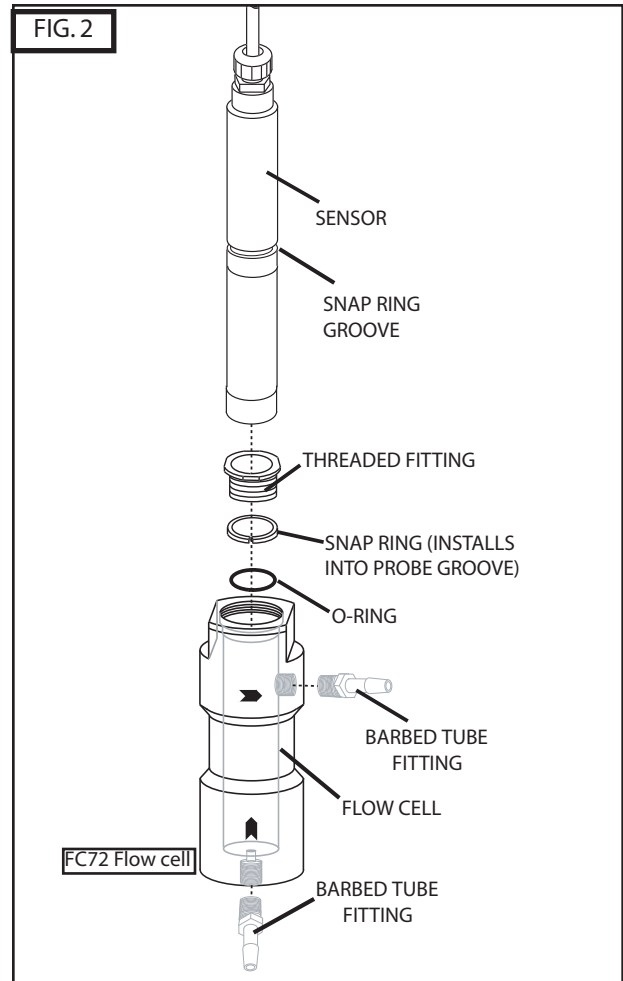

## SECTION 6.0 ELECTRICAL INSTALLATION

6.0 ELECTRICAL INSTALLATION. The sensor produces an approximate output of 4 mA in air and 20mA at the top range of free chlorine output (0-2ppm, 0-5ppm, 0-10ppm).

NOTE: The supply voltage to the Sensor must be 12-24 V DC with minimum of 250 mA. Maximum load is 1 Watt. The sensor has 3 wires, red (+), black (-) and clear (shield). Twist together or solder black and clear if instrument does not have separate ground. If a separate ground is available such as for PLC's connect clear (shield) to it. Attach the red wire to the power supply positive terminal (+) and the black wire to the PLC or DVM positive (+) terminal. Connect a wire (customer supplied) from the power supply negative (-) and the PLC or DVM (-). See FIG 3. The Sensor will require several minutes to stabilize after power is supplied to it.

## SECTION 7.0 SENSOR CONDITIONING

7.0 SENSOR CONDITIONING The sensor requires conditioning prior to generating stable values.

- a. For new Sensors, allow the Sensor to run for at least 4 hours before calibration.
- b. If the Sensor will be un-powered for 2 hours or more, run for 3 hours prior to use.
- c. After membrane/electrolyte replacement, allow the Sensor to run for at least 4 hours.

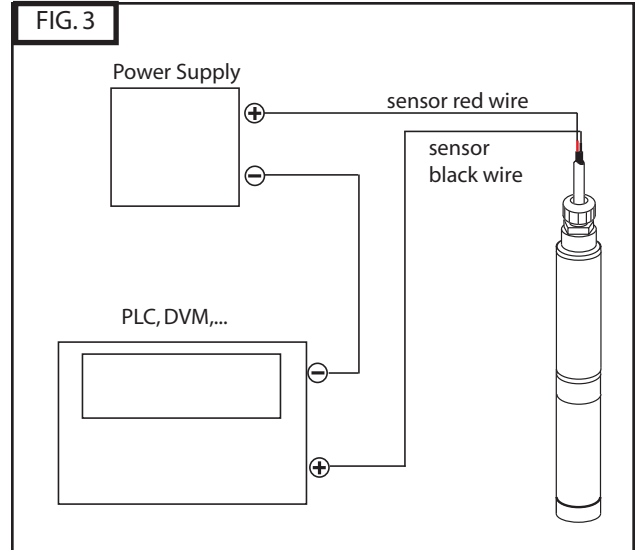



### SECTION 8.0 CALIBRATION

**IMPORTANT NOTE:** SENSORS ARE SUPPLIED FACTORY CALIBRATED WITH A 4-20mA SIGNAL OUTPUT CORRESPONDING TO THEIR SPECIFIC RANGE (0-2, 0-5 OR 0-10ppm). SPAN CALIBRATION IS NECESSARY WHEN RECEIVING A NEW SENSOR SINCE YOUR CONDITIONS MAY VARY FROM THOSE USED AT THE FACTORY FOR SPAN CALIBRATION. THE ZERO POINT CALIBRATION IS NOT NECESSARY SINCE THE ZERO SETTING IS VERY STABLE.

PERIODIC CALIBRATION ( ABOUT ONCE PER WEEK) IS RECOMMENDED. THIS IS USEFUL IN TRACKING SENSOR FAILURES AS WELL.

#### 8.1 Removal of cord grip to access ZERO and SPAN potentiometers inside the sensor body:

- Remove top nut of cord grip as shown in FIGURE 4.
- Remove remaining cord grip as shown in FIGURE 5. A wrench may be required.

#### 8.2 Slope Calibration:

- Determine the free chlorine content using a diethyl-p-phenylenediamine (DPD) colorimeter test kit (see FIGURE 9), not included with ClO<sub>2</sub> sensor and flow cell.
- Measure Free Chlorine content with sensor. Make sure that calibration flow rate and pH matches flow rate when measuring sample since probe output is flow rate and pH dependent. Make sure pH is within 5.5-8.0 range.
- Adjust the span potentiometer to the desired mA (see FIGURES 9 & 9A)
- Repeat this slope calibration one day after sensor is initially installed.
- Repeat the slope calibration monthly.

### SECTION 9.0 SENSOR STORAGE

**9.0 STORAGE.** Store sensor at 5° C- 50° C ONLY and maximum humidity of 90% (non-condensing).

- Short Term Storage (1 week or less): Store in Flow cell with water to prevent the probe from drying out.
- Intermediate Term (1 week to 1 month): Store in cap, bottle, or beaker with water to keep membrane wet.
- Long Term (1 month or longer): Remove Membrane Cap and store completely immersed in tap water. Turn sensor upright and shake it to remove fill solution from inside the sensor.
- Electrolyte bottle shelf-life = 1 year from date of manufacture(see expiration date on bottle)

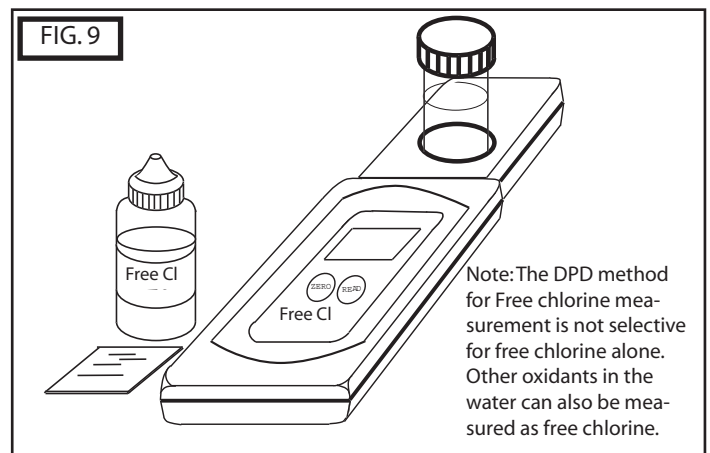
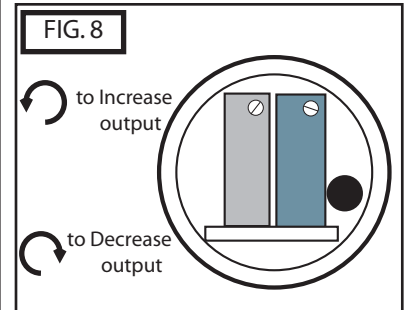
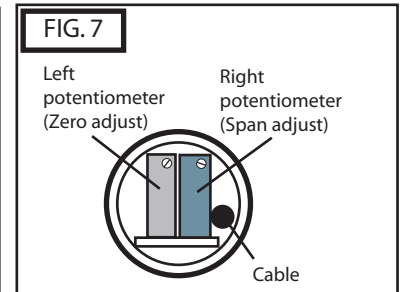
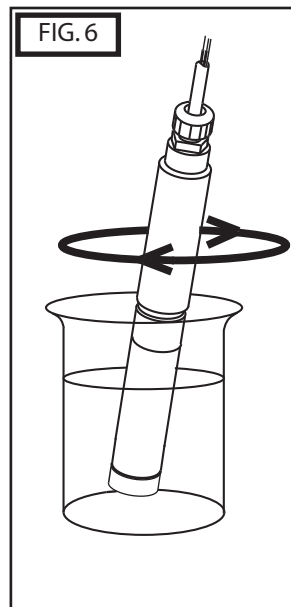
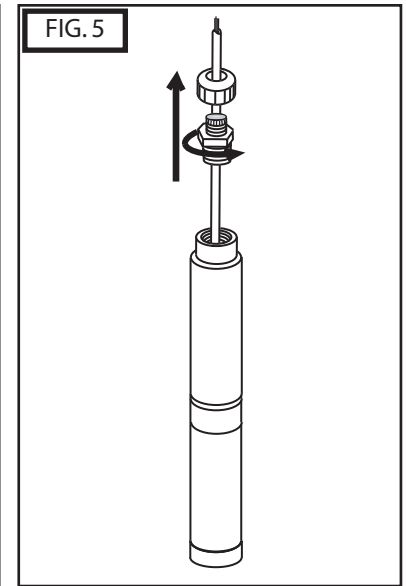
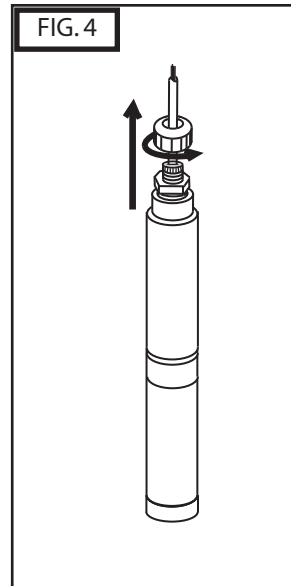

Note: The DPD method for Free chlorine measurement is not selective for free chlorine alone. Other oxidants in the water can also be measured as free chlorine.

# PRODUCT INSTRUCTION SHEET

## SECTION 10.0 SENSOR MAINTENANCE/RECONDITIONING

10.1 GENERAL MAINTENANCE. Service the sensor regularly (weekly is suggested)

10.2 MEMBRANE CAP REPLACEMENT. If membrane replacement is required, a new cap with preinstalled membrane must be used. Order FCLA-2016 replacement membrane cap and FCLA-2015 refill solution. To change membrane cap (do the following over a sink or washbasin):

- turn sensor upside down with cap facing upward
- rotate cap counter-clockwise to remove (see FIG 10).
- fill sensor body with electrolyte using needle and bottle of refill solution (see FIG. 11)
- install a new membrane cap by threading cap onto sensor rotating cap clockwise (opposite of FIG 10)

10.3 MEMBRANE CAP/SENSOR CLEANING. Rinse cap with water only. If cap does not clean, replace with new one.

## SECTION 11.0 SENSOR TROUBLESHOOTING

### 11.1 CALIBRATION PROBLEMS

- Sensor output *HIGHER* than DPD test
  - Run in time too short
  - Membrane cap damaged
  - Interference from water contaminants (see Specifications, "Cross Sensitivity")
  - Cable short circuit or damage
  - pH value less than pH 5.5
- Sensor output *LOWER* than DPD test
  - Run in time too short
  - Deposits on Membrane cap
  - Flow rate too low
  - Air bubbles on membrane
  - Surfactants in water
  - pH value more than pH 8.0
  - No electrolyte in membrane cap
- Sensor output is 4mA (zero ppm)
  - Run in time too short
  - Only bound chlorine present
  - Chlorine content below detection limit
  - Sensor not wired correctly (See SECTION 6.0 of this manual)
  - Defective sensor
- Sensor output *UNSTABLE*
  - Air bubbles on membrane
  - Membrane damage
  - Non-sensor problem

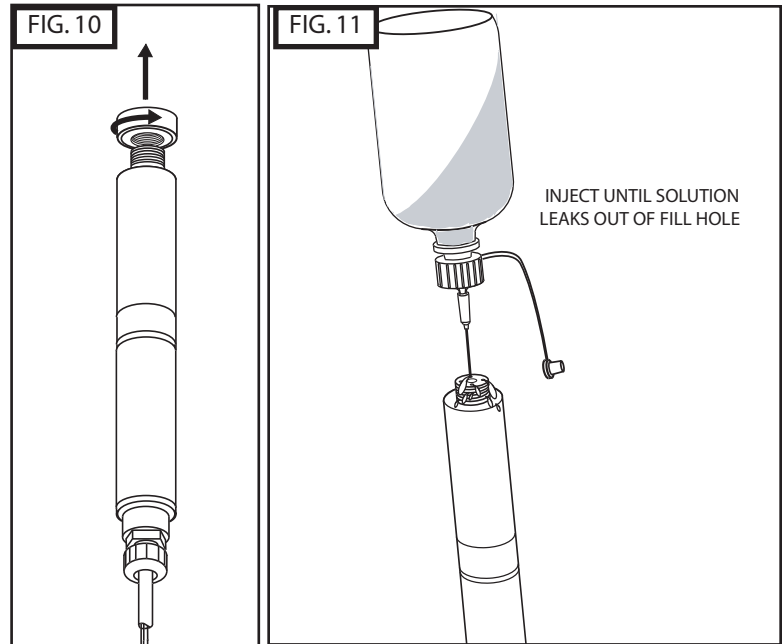

### TROUBLESHOOTING CHART

Symptom	Possible Cause	Solution/Remedy
The sensor cannot be calibrated- output is <i>HIGHER than</i> DPD Test	<ol style="list-style-type: none"> <li>Run in time too short</li> <li>Membrane cap damaged</li> <li>Interference from contaminants</li> <li>DPD chemicals bad</li> <li>pH value &lt; pH 5.5</li> <li>Temperature increased since cal</li> </ol>	<ol style="list-style-type: none"> <li>See Sec 5.0 -CONDITIONING</li> <li>Replace cap - See Sec 8.0</li> <li>See SPECIFICATIONS</li> <li>Use new DPD kit</li> <li>Increase pH (5.5-8.0) See SPECIFICATIONS</li> <li>Match calibration temp.</li> </ol>
The sensor cannot be calibrated- output is <i>LOWER than</i> DPD Test	<ol style="list-style-type: none"> <li>Run in time too short</li> <li>Deposits on membrane cap</li> <li>Flow rate too low</li> <li>Air bubbles on membrane</li> <li>Surfactants in water</li> <li>pH &gt; pH 8.0</li> <li>No electrolyte in cap</li> <li>Temperature decreased since cal</li> <li>Organic chlorination agents present in water</li> </ol>	<ol style="list-style-type: none"> <li>See Sec 7.0 -CONDITIONING</li> <li>Remove deposits or replace cap if cleaning ineffective.</li> <li>increase flow - See SPECIFICATIONS</li> <li>Remove and re-install sensor to remove bubbles.</li> <li>Remove surfactants and replace cap</li> <li>Lower pH (5.5-8.0) See SPECIFICATIONS</li> <li>Add new electrolyte, run in sensor and re-calibrate</li> <li>Increase temp to match cal</li> <li>Use chlorinating agents per DIN 19643</li> </ol>
Sensor output is 4mA (0 ppm)	<ol style="list-style-type: none"> <li>Only bound chlorine present NO FREE CHLORINE</li> <li>Run in time too short</li> <li>Chlorine content below limit</li> <li>No electrolyte in cap</li> <li>Sensor electrical connection wrong</li> </ol>	<ol style="list-style-type: none"> <li>Check for Chloramine with appropriate DPD test. Replace water/ Rechlorinate.</li> <li>See Sec 7.0 -CONDITIONING</li> <li>Add chlorine and repeat calibration</li> <li>Refill electrolyte</li> <li>See SECTION 6.0</li> </ol>
Unstable output from sensor	<ol style="list-style-type: none"> <li>Air bubbles on sensor membrane</li> <li>Membrane damaged</li> <li>Non-sensor problem</li> </ol>	<ol style="list-style-type: none"> <li>Tap to remove bubbles</li> <li>Replace membrane, run in sensor and recalibrate.</li> <li>check PLC or I/O device</li> </ol>

Parts covered by this product instruction sheet include: FCL202, FCL205, FCL210, FC72, FCLA-2015, FCLA-2016



### SECTION 12.0 SENSOR SPECIFICATION

12.1 OPERATING SPECIFICATIONS. Follow all operating specifications, especially for pH and flow rate as noted in the specification tables below.

#### TECHNICAL SPECIFICATIONS

<b>SENSOR</b>	
Dimensions:	8.2"L x 1" dia
Body Material:	Black PVC
Membrane Material:	polyethersulfone
O-ring material:	Viton <sup>®</sup>
Cathode:	Gold
Anode:	Silver chloride (AgCl)
Cable:	2 -conductor shielded, 10ft (3mtr) tinned wire leads
<b>FLOW CELL</b>	
Dimensions:	5.58"H x 2.25"DIA
Material:	Acrylic
Connections:	1/4" NPT inlet and outlet

#### OPERATING SPECIFICATIONS

Operating temperature range:	0-45 degC
Maximum operating pressure:	1 bar/14.7 psi/1atm
Flow rate minimum:	.20 gpm
Flow rate maximum:	0.6 ppm
pH range:	5.5-9.0
Output signal:	4.0+/- 0.2mA in air (zero) 20mA +/- 0.2mA at high range (2, 5 or 10ppm)
Power Requirement:	12-24 VDC, 250 mA minimum
Cross-Sensitivity:	ClO <sub>2</sub> , ozone, bromine
Chemical Compatibility:	up to 50% ethanol/water or up to 50% glycerol/water

#### MAINTENANCE/REPLACEMENT PARTS

FC72C	Flow Cell, 1/4 inch FNPT inlet and outlet, includes: 2 each 1/4" barbed tube fittings, clamp, threaded flow cell installation fitting
FCLA-2015	Free Chlorine sensor fill solution, 30mL, 1 each
FCLA-2016	FCL Replacement premembraned cap, 1 each

#### FC72 FLOW CELL DIMENSIONS

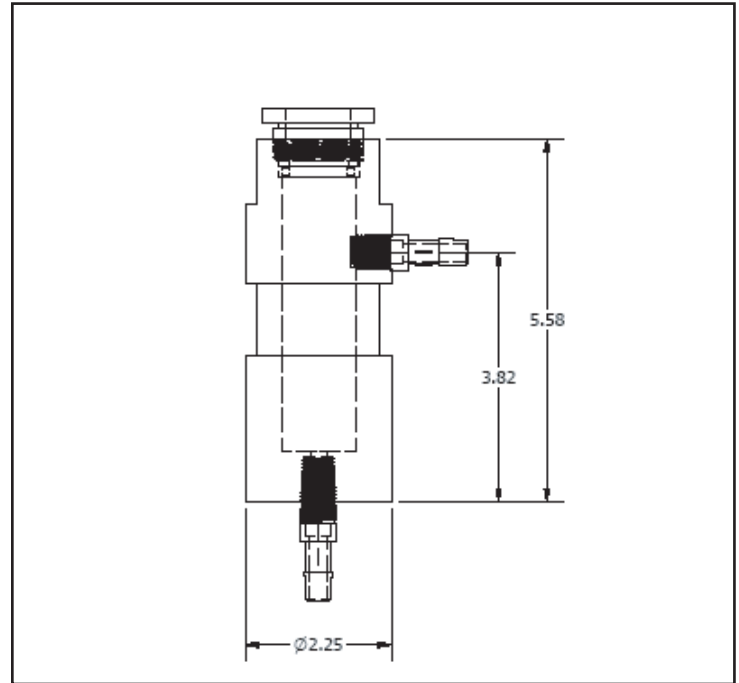

#### SENSOR AND FLOW CELL INSTALLATION DIMENSIONS

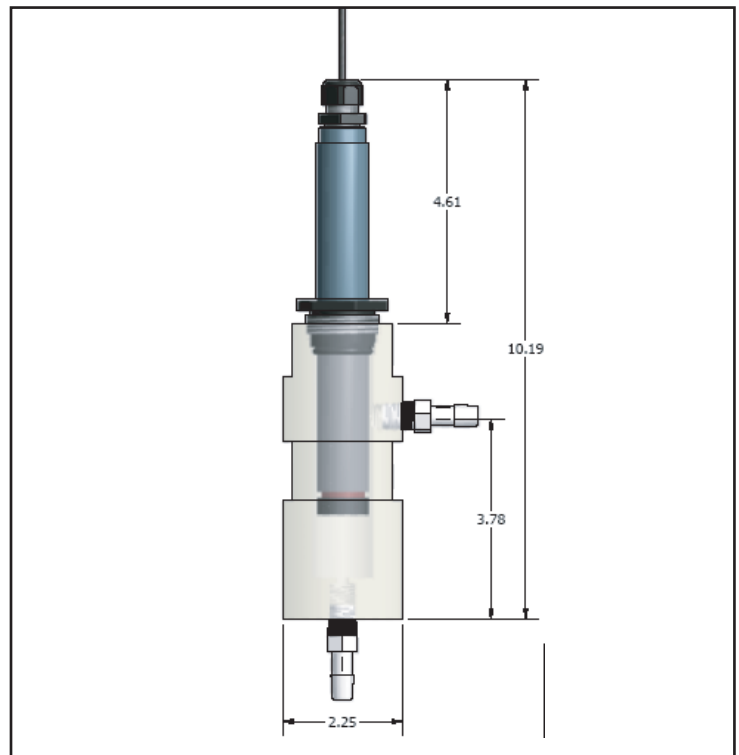

11751 Markon Dr. Garden Grove, CA. 92841 USA  
Tel: 714-895-4344 \* Fax: 714-894-4839  
www.sensorex.com

Parts covered by this product instruction sheet include: FCL202, FCL205, FCL210, FC72, FCLA-2015, FCLA-2016