

# Polymer Body and Glass Body, Sealed Reference Electrodes

## Product Instructions

### Section 1.0 Introduction

The sealed design of the epoxy body Reference Electrode eliminates the need to add filling solutions, minimizes reference dry-out, and allows the electrode to be used in up to 100 psig systems without the need for external pressurization.

### Helpful Operating Techniques

1. As shipped, a protective cap that serves to keep the reference from drying covers the electrode tip. This cap is a snug fit and it contains a pressure relief hole to facilitate removal and installation. As supplied, this hole is covered by a piece of vinyl tape to retain moisture inside the cap. Before removing or reinstalling this cap, the tape must be removed to expose the pressure relief hole as shown in FIG 1.
2. Although vigorous stirring in the laboratory or high velocities in flowing systems brings a sample, calibration standard or rinse solution to reference junction faster and improves speed of response, care must be taken to keep from striking another surface or being hit by a stirring rod, etc. In the laboratory, the electrode should be mounted on the holder that comes with the meter and, if possible, the holder's rod marked with tape to prevent the electrode from being lowered so far that it strikes the bottom of the container or a stirring rod. The electrode never should be used as a stirring rod (SEE FIG 2).
3. After exposure to a sample, calibrating standard or rinse solution, minimize carryover by a snap action shaking of the electrode to remove residual drops of solution as shown in FIG 3. As a rinse solution, use a part of the next solution to which the electrode will be exposed. This action will also minimize contamination from carryover.
4. When calibrating, keep the temperature of the calibrating standard within a few degrees Celsius of some value that is conveniently maintained at your location. Doing this will minimize changes in readings due to temperature changes.
5. The type of Reference Electrode used will affect the millivolt readings of both samples and calibration standards. The two commonly used Reference Electrodes differ by having internals made of silver/silver chloride (Ag/AgCl) or internals made of calomel. Reference Electrodes that are accompanied by these instructions have Ag/AgCl internals and have 3.5 M KCl gels. 3.5M KCl reference electrodes will give a reading of about +40 mV as compared to Reference Electrodes with calomel internals and saturated KCl solutions.

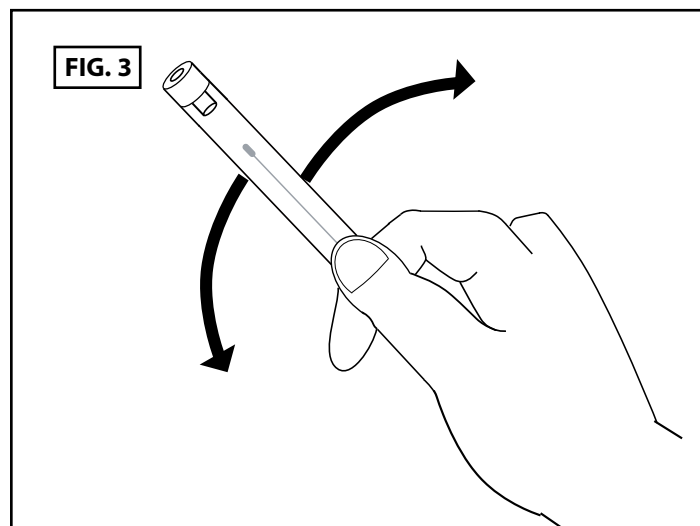
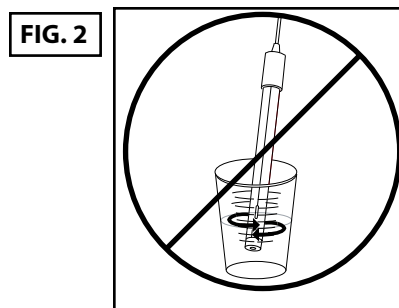
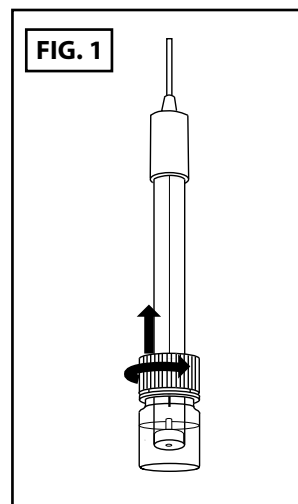

## Section 2.0 Calibration Procedure

As a general rule, follow the procedures recommended by the Meter manufacturer keeping in mind the Helpful Operating Techniques given above. The frequency of calibration is a function of the Reference electrode, the pH or ORP half-cell, and the meter. They should be calibrated together with the calibration frequency determined by experience. The following step-wise procedure has been found useful:

### Laboratory Procedure

1. Remove the vinyl tape from the Reference electrode's protective cap to expose the pressure relief hole. Remove and save the cap.
2. Rinse the electrode with de-ionized or tap water by carefully stirring it in a beaker containing this rinse solution (FIG 4).
3. Remove the electrode from the rinse water.
4. Repeat steps 1-3 for the pH or ORP half-cell.
5. Pour Calibration Standard solution into a small beaker to about a 3/8" (1cm) depth. For best results, the Calibration solution should be as near as possible to the temperature of the process sample to be measured.
6. Insert the Reference and pH or ORP electrodes into the solution and gently stir.
7. Allow the reading to stabilize and compare it to the standard solution's value. Typically, the meter reading should agree within a few millivolts of the Calibration solution value.
8. If the electrode is to be checked in a different standard solution, repeat steps 2 through 6.

### Reference to Reference Calibration

1. Remove the vinyl tape from the Reference electrode's protective cap to expose the pressure relief hole. Remove and save the cap.
2. Place the Reference Electrode into a beaker of tap water or some Calibration Standard Solution with a known "good" Reference, pH, or ORP electrode. Connect one lead from the meter to the Reference Electrode and the second lead to the reference side of the known "good" electrode (i.e. the shell of the electrode's connector) as shown in FIG 5. Regardless of the solution, the meter should read near zero millivolts (near 7.0 on the pH scale) if the Reference Electrode and the "good" electrode give the same reference value.

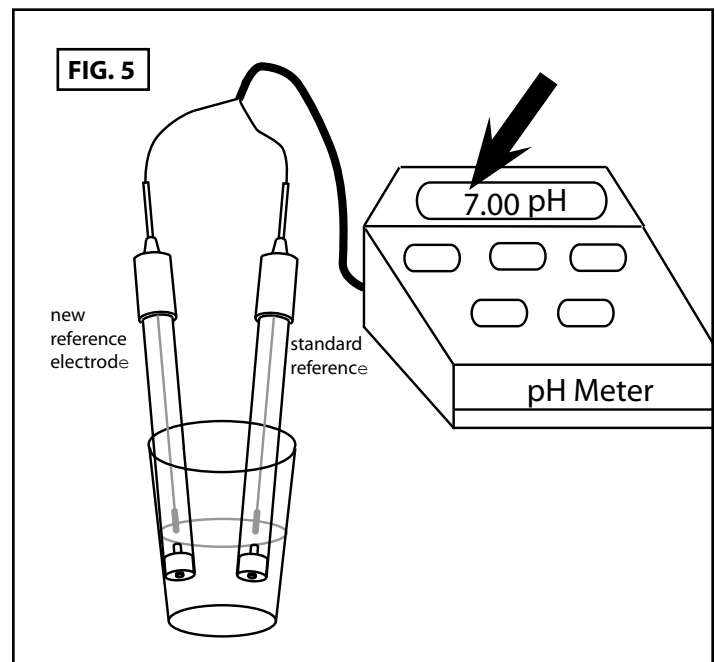
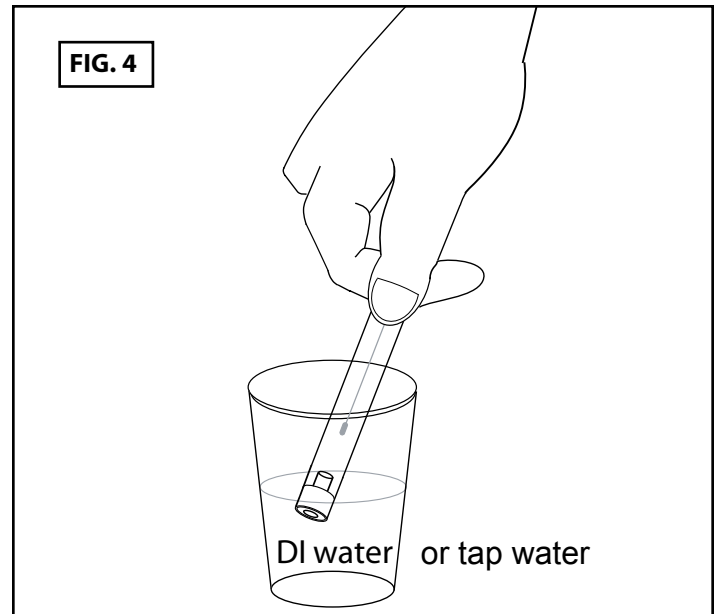

## SECTION 2.0

### Calibration Procedure (Cont.)

#### Grab Sample/In-Line Calibration (FIG 6)

1. Collect a sample of solution the electrode is monitoring (Take it from a place as close to the electrode as possible).
2. Just when the sample is collected, observe the meter reading and make a note of that value.
3. As quickly as possible, analyze the collected sample by an appropriate means.
4. Now, if necessary, adjust the meter reading to reflect the difference between the analyzed sample and the meter reading when the sample was collected. For example, if the meter read 5 units when the sample was collected and the analyzed sample value was 7 units, the meter would be adjusted + 2 units from whatever its present reading is.

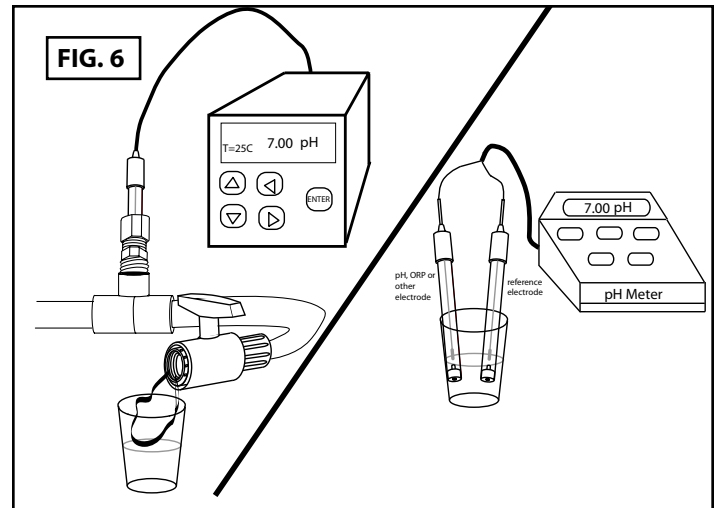

## SECTION 3.0

### Electrode Storage

When readings are made infrequently, for example, several days or weeks apart, the electrode can be stored simply by replacing it in its soaker bottle. If you did not save the storage solution, pH4 buffer is a good alternative. (SEE FIG 7).

## SECTION 4.0

### Cleaning Procedure

Coatings that coat the reference junction can cause reading errors and coatings must be removed if accurate results are to be obtained. We first suggest a rinse in 5% HCl for five minutes. Some coatings may not dissolve in HCl and so you can try a liquid detergent. If proteins are in the sample, Terg-A-Zyme®, a powdered detergent that contains enzymes that breakdown proteins, is recommended. Alcohol may be used for stubborn organic deposits but do not soak electrode in it.

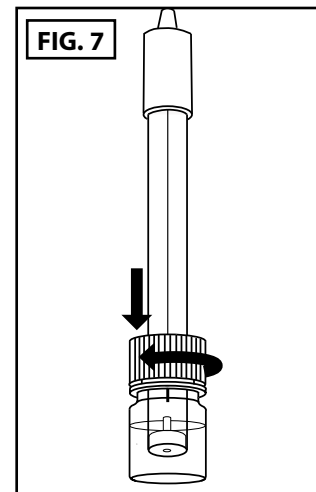

## Specifications

<b>Reference Element</b>	Ag/AgCl
<b>Electrolyte</b>	3.5M KCl, saturated with AgCl for all models ending with "R"  saturated KNO <sub>3</sub> /3.5M KCl for all models ending in "RD"

### 3.5 M KCl, Ag/AgCl Electrode Voltage Output

Power Requirement	Voltage
10C/50F	215 +/- 6mV
15C/59F	212 +/- 6mV
20C/68F	208 +/- 6mV
25C/77F	205 +/- 6mV
30C/86F	201 +/- 6mV
35C/95F	197 +/- 6mV