

TERMINALS 1 AND 5 ARE TIE POINTS WITH NO CONNECTION TO THE INTERNAL CIRCUITRY OF THE AMPLIFIER.

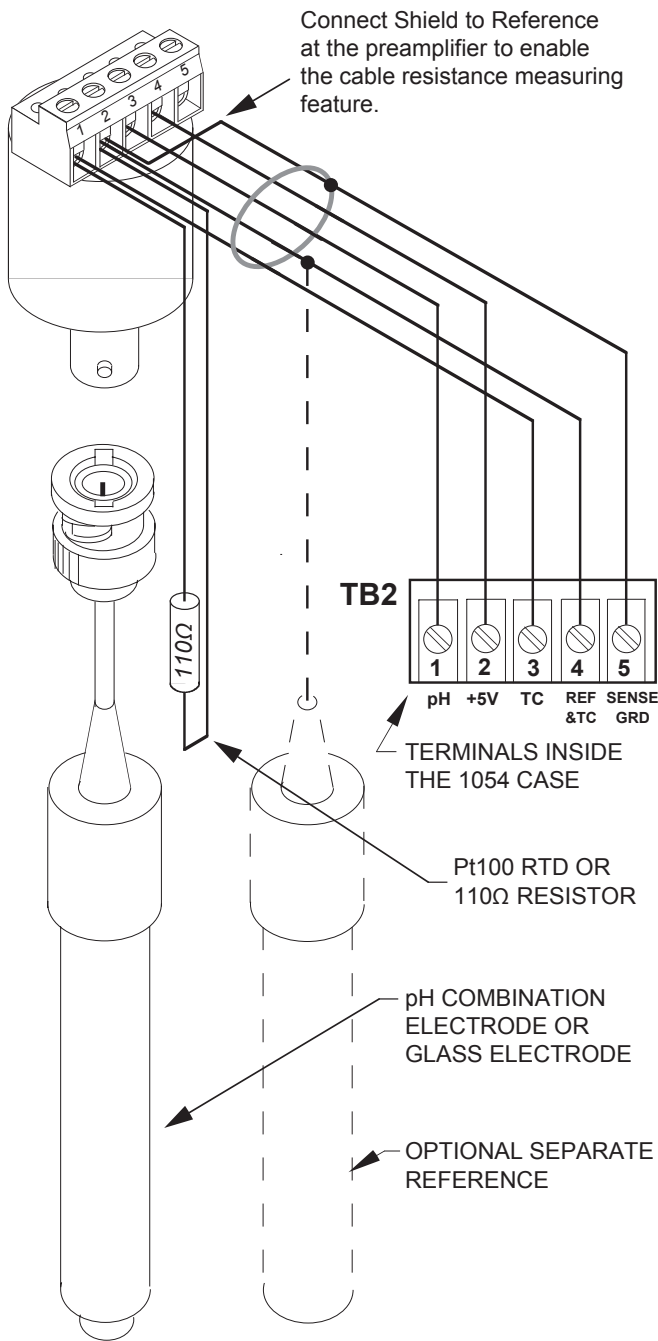

**NOTES :**

**GENERAL**

OUTPUT TO THE INSTRUMENT FROM THE PREAMP IS UNITY GAIN, NORMAL POLARITY. 1054 POWER SUPPLY IS +5V.

WHEN A COMBINATION ELECTRODE IS USED, REFERENCE CONNECTION IS MADE THROUGH THE BNC CONNECTOR. USE OF A SEPARATE REFERENCE REQUIRES A CONNECTION TO TERMINAL 2, AS SHOWN IN DRAWING AT LEFT.

**TEMPERATURE COMPENSATION**

STANDARD 1054 TC IS ACCOMPLISHED WITH A POSITIVE COEFFICIENT PLATINUM RTD THAT READS 110Ω AT 25°C.

**SHIELDING**

TAKE CARE NOT TO ALLOW THE BNC SHIELD (REFERENCE LEAD) TO CONTACT METAL PIPING OR J-BOXES AT ANY POINT, AS THIS WILL SHORT THE REFERENCE CELL TO EARTH GROUND, AND CAUSE UNSTABLE READINGS. SHIELDING OF THE CABLE FROM AMPLIFIER TO INSTRUMENT IS REQUIRED. CONNECT IT TO REFERENCE AT THE SENSOR END ONLY, AND MAKE SURE THAT IT DOES NOT TOUCH ANY OF THE OTHER LEADS.

**POWER**

+3V TO +9V DC.

CURRENT DEMAND W/O LOAD < 1mA

CURRENT DRIVE: 0.5mA SINK; 25mA SOURCE.

**THIS AMPLIFIER WAS DESIGNED FOR USE WITH THE UNILOC/ROSEMOUNT MODEL 1054, AND WILL ALSO INTERFACE WITH BECKMAN SOLU COMP™ pH/ORP METERS.**

**IT CAN BE USED WITH ANY METER THAT REQUIRES A UNITY GAIN, NORMAL POLARITY INPUT, AND HAS A SINGLE POSITIVE SUPPLY OF +3V TO +30V AVAILABLE.**

SPECIAL NOTE: The 1054 has slight instability problems and poor noise immunity. Two fixes will greatly improve measurement stability. First, connect a 0.02µF capacitor between terminals 1 and 4 in the instrument. Second, run a lead from the earth ground power terminal in the instrument to a piece of metal in the same stream as the pH electrode (this is called a Solution Ground). The solution ground is the more effective of the two. For a flow-through sensor, a metal tee is recommended.

		11751 Markon Drive	
		Garden Grove, CA. 92841 USA	
		phone: 714-895-4344 fax: 714-894-4839	
DRAWN	TITLE	<b>PREAMPLIFIER WIRING</b>	
CHECKED		<b>U698-03 WITH UNILOC 1054</b>	
APPROVED	SCALE	<b>NONE</b>	DRAWING NO.
	SHEET	<b>1 OF 1</b>	<b>U698-03-1054</b>
			REV. <b>D</b>