

Epoxy Body Conductivity Sensors - Graphite and Platinum Black

MECHANICAL INSTALLATION

SUBMERSION INSTALLATION. The CS150 or CS200 electrode can be submersion mounted in a tank for conductivity measurement using gland and nut fitting FC50P (1/2" NPT) or FC75P (3/4" NPT). The FC50P or FC75 must first be inverted so the nut is pointed downward. Loosen the the nut by turning clockwise (remember that fitting is inverted!). Slip electrode through hole in nut until desired depth is reached. Tighten nut (hand-tight) by turning counterclockwise. Refer to FIG. 1 and FIG. 2.

IN-LINE INSTALLATION. Mounting in-line is also possible using FC50P or FC75P fittings. For in-line mounting it is suggested that the sensor be mounted through the side of the tee as shown in FIG. 3 and FIG.4. The sensor must also be mounted such that the opening/slot in the body is pointed upward so as to allow any air bubbles to rise out of the sensor and escape with the flow.

ELECTRODE REMOVAL. Simply reverse installation procedures above.

ELECTRICAL INSTALLATION

INSTALLATION FOR ELECTRODES WITHOUT TEMPERATURE SENSOR INCLUDED. The CS150 or CS200 do not include temperature sensors. Each is supplied with 2 connections (RED AND BLACK) and optional ground. Refer to FIG. 5. These wires are for conductivity connection and have no unique polarity. Connect to any conductivity controller or transmitter per the manufacturer's wiring instructions at the connections marked "conductivity" or "cell".

INSTALLATION FOR ELECTRODES WITH TEMPERATURE SENSOR INCLUDED. Electrodes with part number CS150TC-___ or CS200TC-___ include a temperature sensor to provide a temperature signal so that your conductivity instrument can perform temperature compensation (correct conductivity value to 25C or 20C depending on instrument manufacturer.) The temperature wires are GREEN and WHITE. See FIG 6 for wiring details. These temperature wires can be connected to the instrument's temperature input in any order since the output is a resistance signal (Ohms). Please note that some meters require a 3 or 4 wire temperature signal input. In these cases, place a jumper wire (for 3-wire type) or 2 jumper wires (4-wire type) from the original lead to open temperature inputs. Please refer to manufacturer's manual for details.

Parts covered by this product instruction sheet include:
CS150, CS150TC, CS200, CS200TC

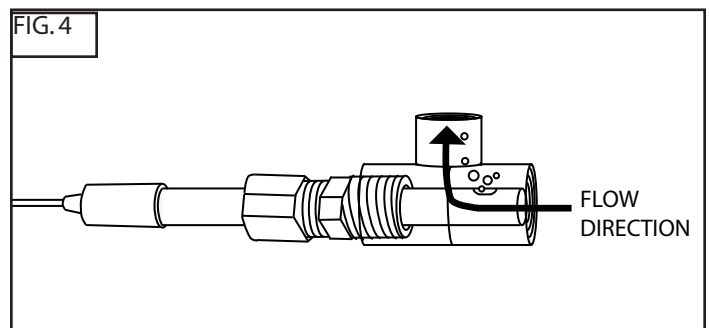
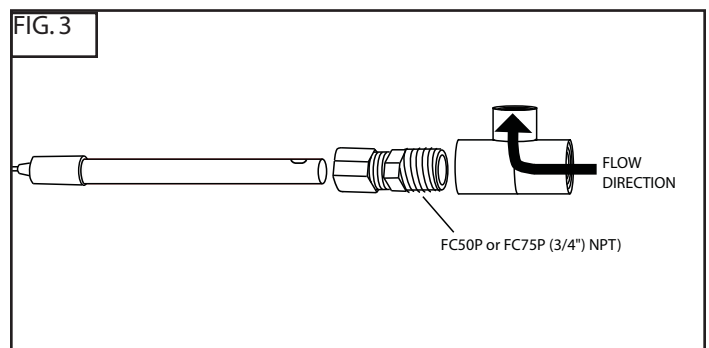
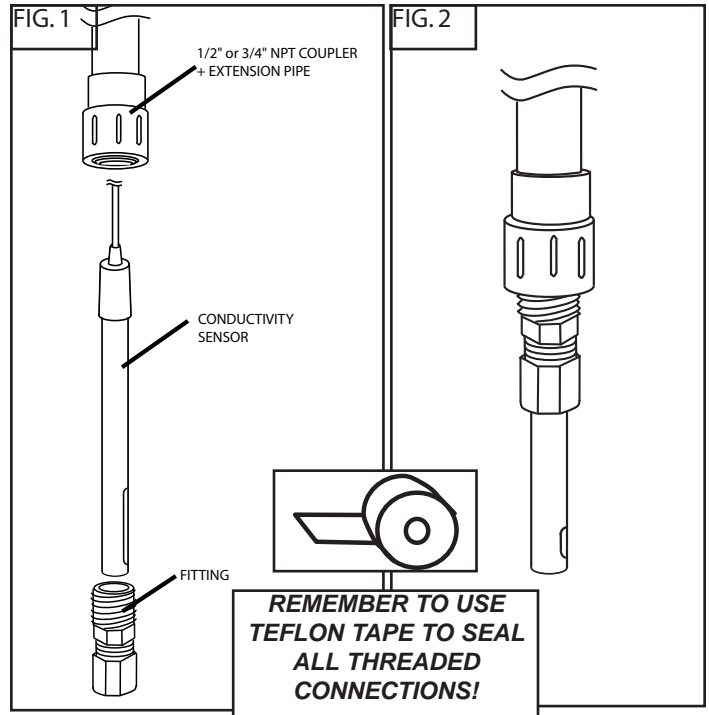

CALIBRATION

CALIBRATION. Calibrate sensor according to meter/controller manufacturer's instructions using known certified conductivity standards. Contact Sensorex or go to www.sensorex.com for a complete selection of calibration standards. Be sure and calibrate in large beaker or bucket stirring sample with electrode. Avoid bubbles as much as possible as bubbles cause erroneous readings.

CARE AND CLEANING

CLEANING. CS150 and CS150TC electrodes have a graphite measuring surface. Clean surfaces with gentle detergent or 5% HCl in cup or beaker. Do not sand or abrade the graphite surface as abrasion changes the surface area and will cause erroneous readings.

CS200 and CS200TC electrodes have a platinum black coated platinum measuring surface. **DO NOT TOUCH PLATINUM BLACK SURFACE SINCE IT WILL REMOVE PLATINUM BLACK COATING WHICH CANNOT BE REPLACED.** Clean with 5%HCl or detergent.

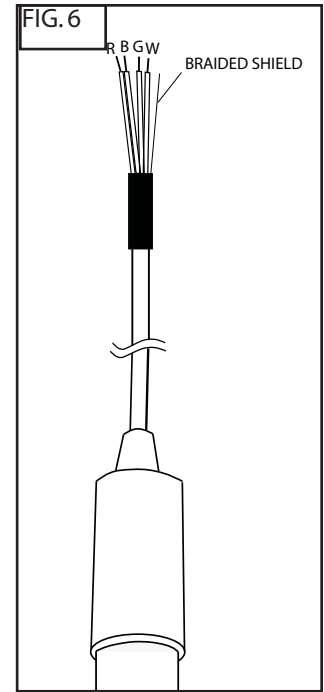
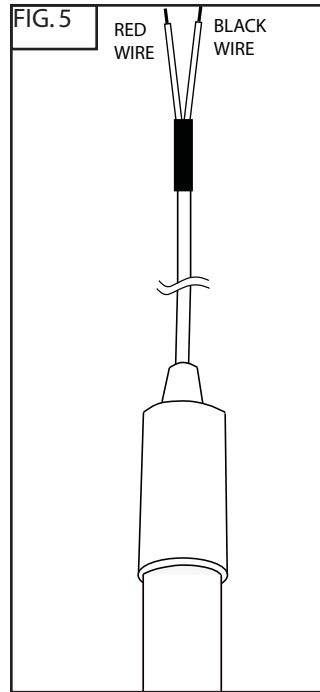

Sensorex[®]

11751 Markon Dr.
Garden Grove, CA 92841 USA

Tel: 714-895-4344
Fax: 714-894-4839
E-mail: info@sensorex.com
www.sensorex.com

Parts covered by this product instruction sheet include:
CS150, CS150TC, CS200, CS200TC

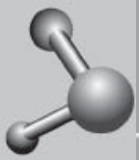

Epoxy Body Conductivity Sensors - Graphite and Platinum Black

MECHANICAL INSTALLATION

SUBMERSION INSTALLATION. The CS150 or CS200 electrode can be submersion mounted in a tank for conductivity measurement using gland and nut fitting FC50P (1/2" NPT) or FC75P (3/4" NPT). The FC50P or FC75 must first be inverted so the nut is pointed downward. Loosen the the nut by turning clockwise (remember that fitting is inverted!). Slip electrode through hole in nut until desired depth is reached. Tighten nut (hand-tight) by turning counterclockwise. Refer to FIG. 1 and FIG. 2.

IN-LINE INSTALLATION. Mounting in-line is also possible using FC50P or FC75P fittings. For in-line mounting it is suggested that the sensor be mounted through the side of the tee as shown in FIG. 3 and FIG.4. The sensor must also be mounted such that the opening/slot in the body is pointed upward so as to allow any air bubbles to rise out of the sensor and escape with the flow.

ELECTRODE REMOVAL. Simply reverse installation procedures above.

ELECTRICAL INSTALLATION

INSTALLATION FOR ELECTRODES WITHOUT TEMPERATURE SENSOR INCLUDED. The CS150 or CS200 do not include temperature sensors. Each is supplied with 2 connections (RED AND BLACK) and optional ground. Refer to FIG. 5. These wires are for conductivity connection and have no unique polarity. Connect to any conductivity controller or transmitter per the manufacturer's wiring instructions at the connections marked "conductivity" or "cell".

INSTALLATION FOR ELECTRODES WITH TEMPERATURE SENSOR INCLUDED. Electrodes with part number CS150TC-___ or CS200TC-___ include a temperature sensor to provide a temperature signal so that your conductivity instrument can perform temperature compensation (correct conductivity value to 25C or 20C depending on instrument manufacturer.) The temperature wires are GREEN and WHITE. See FIG 6 for wiring details. These temperature wires can be connected to the instrument's temperature input in any order since the output is a resistance signal (Ohms). Please note that some meters require a 3 or 4 wire temperature signal input. In these cases, place a jumper wire (for 3-wire type) or 2 jumper wires (4-wire type) from the original lead to open temperature inputs. Please refer to manufacturer's manual for details.

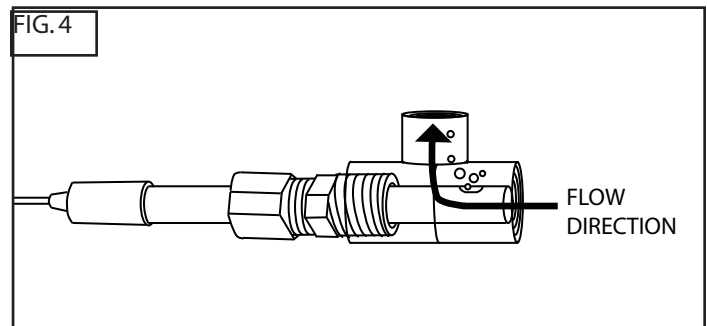
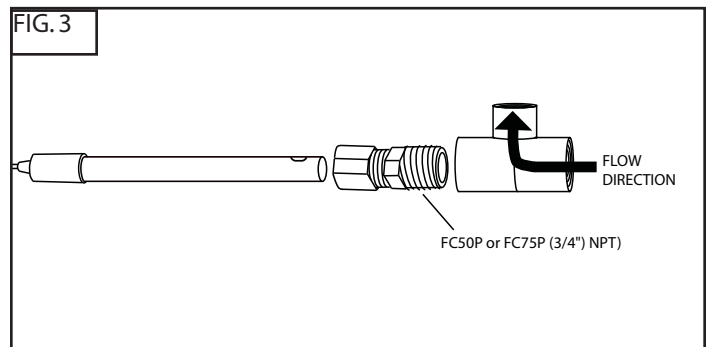
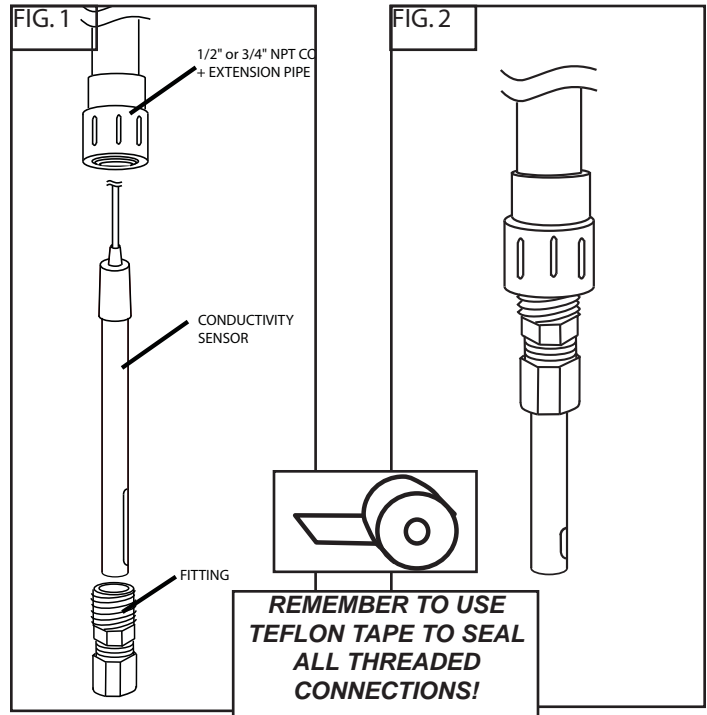

CALIBRATION

CALIBRATION. Calibrate sensor according to meter/controller manufacturer's instructions using known certified conductivity standards. Contact Sensorex or go to www.sensorex.com for a complete selection of calibration standards. Be sure and calibrate in large beaker or bucket stirring sample with electrode. Avoid bubbles as much as possible as bubbles cause erroneous readings.

CARE AND CLEANING

CLEANING. CS150 and CS150TC electrodes have a graphite measuring surface. Clean surfaces with gentle detergent or 5% HCl in cup or beaker. Do not sand or abrade the graphite surface as abrasion changes the surface area and will cause erroneous readings.

CS200 and CS200TC electrodes have a platinum black coated platinum measuring surface. **DO NOT TOUCH PLATINUM BLACK SURFACE SINCE IT WILL REMOVE PLATINUM BLACK COATING WHICH CANNOT BE REPLACED.** Clean with 5% HCl or detergent.

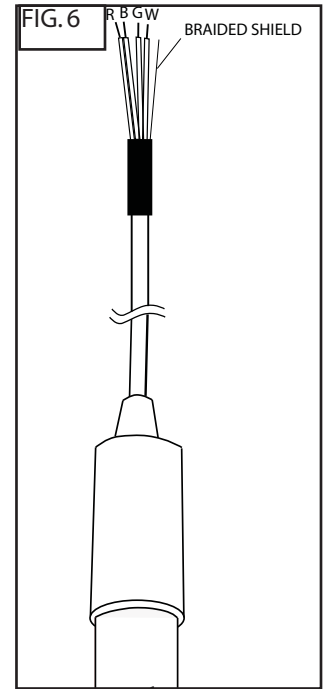
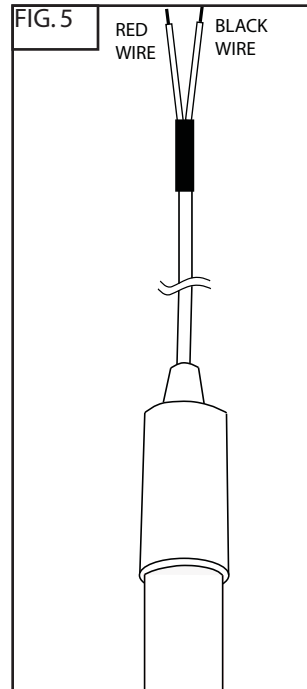

Sensorex[®]

11751 Markon Dr.
Garden Grove, CA 92841 USA

Tel: 714-895-4344
Fax: 714-894-4839
E-mail: info@sensorex.com
www.sensorex.com

Parts covered by this product instruction sheet include:
CS150, CS150TC, CS200, CS200TC